

**KIOSKedia**  
International  
Design Awards  
2023

**[award.kioskedia.com](http://award.kioskedia.com)**

# Contents

<b>1</b>	—————	KIOSKedia International Design Awards
<b>2</b>	—————	Founder and Co-founder of KIOSKedia
<b>3</b>	—————	Expert Jury
<b>5</b>	—————	Gold Sponsors
<b>7</b>	—————	Media Sponsor
<b>8</b>	—————	Academic Sponsors
<b>9</b>	—————	Mains Winners
<b>31</b>	—————	Honorable Mentions



## KIOSKedia International Design Awards

---

The sole mission of the award is to seek out talented subject designers and help promote their work for the public and professionals in the world to see.

Furthermore, our objective is to establish a single creativity rating in the field of subject design, based on your expertise and knowledge of the world of architecture, interior design, industrial design, lighting, furniture, Graphic and Photography.

---

## Founder and Co-founder of KIOSKedia International Design Awards



**Fereshteh Haji Gholami** is an architect, interior designer and product designer. She was born in Tehran-Iran and graduated from the UPM University of Malaysia in the field of architecture/sustainable design. She is founder of KIOSKedia International Academy, KIOSKedia International Design Awards as well as KIOSK International Magazine which is based in Iran and Malaysia where she also works as the Editor-in-Chief. She has taken on major roles such as university lecturer, Jury of IDA International Design Awards (USA), KIOSKedia International Design Awards (Iran), Inspireli International Design Awards (Czech Republic) and she has won 13 international awards from prestigious design competitions. She is now conducting vast research on sustainable and energy efficient projects and products and, on the other hand, she has curated miscellaneous international conferences, scientific workshops, seminars and exhibitions rooted in architecture, interior design, industrial design and design sub-branches.



**Nima Bavardi** was born in Tabriz, Iran, and showed an early interest in art, beginning his painting journey at a very young age. His initial exhibition of caricatures and paintings took place when he was just 5 years old. Bavardi holds a bachelor's degree in industrial design from the Central Tehran branch of IA University. In 2015, he successfully completed his master's degree in industrial design. His passion lies in designing products for everyday use, and he has received numerous international design awards throughout his professional career. Bavardi, who is also a university lecturer, has been a jury member of prestigious awards such as A'Design Award in Italy since 2018, INDUSTART Awards in Ukraine, The SIT & LIT Award in Switzerland, Edison Awards in the USA, Inspireli Awards in the Czech Republic, Taiwan International Student Design Competition in Taiwan, KIOSKedia Awards in Iran, and The Stevies IBA in the USA. Furthermore, he serves as an advisor to ADP for Western Asia and is a full member of IAD, IBSP, ICCI, IDC AIBA, and TCA. In recognition of his talent, Bavardi was recently selected as one of the world's top 40 young lighting designers under forty years old at the "40Under40" 2023. As the co-founder of KIOSKedia International Design Awards, he plays a pivotal role in advancing design innovation and achieving industry recognition.

## EXPERT JURY

36 architecture and design experts from over 16 countries make up this year's KIOSKedia international design awards jury panel. The juries are a selected panel of industry experts from each of the 7 KIOSKedia disciplines – Architecture, Interior Design, Furniture and Decorative Items, Lighting, and Industrial Product Design. They are among the most experienced architects and professional designers, owners of prominent brands, full professors of the world's top universities and journalists, and rely on their extensive experience with up-to-date methodology and standard factors to evaluate projects. They select significant designs and introduce them to the world. Designs that can improve the quality of human life and the world and create a bright future for the next generations.



LUCA DEBONA  
ITALY



FELIX ALEJANDRO HERNANDEZ  
MEXICO



ALESSANDRO MATTIA  
ITALY



FERESHTEH GHOALMI  
IRAN



NIMA BAVARDI  
TÜRKİYE



KARL JOHAN BERTILSSON  
SWEDEN



MOHSEN MOOSAVI  
CANADA



RYU JONG DAE  
SOUTH KOREA

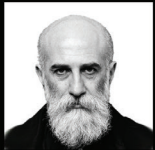

REZA ABEDINI  
IRAN



SOLMAZ FOOLADI  
NETHERLANDS



EMEL BALCI  
TÜRKİYE



MEHRDAD IRAVANIAN  
IRAN



RICHARD YASMINE  
LEBANON



AIDIN ARDJOMANDI  
IRAN



ALI ZOLGHADRI  
IRAN



ALIREZA MASHHADIMIRZA  
IRAN



AIDIN ARJOMAND  
IRAN



CARMEN PASCUAL  
SPAIN



TAHA FAKOURI  
IRAN



SAMUEL LAMAS  
BRAZIL



TUNA MERT  
TÜRKİYE



ARASH BEHESHTI  
IRAN



PAYAM ERAEE  
USA



HOSSEIN MOHAMMADIVAHIDI  
IRAN



GLORIA GIANATTI  
ITALY



SERDAR ACAR  
TÜRKİYE

# KIOSKEDIA INTERNATIONAL DESIGN AWARDS

award.kioskedia.com

KIOSKedia  
KK

GRAND JURY  
PANEL  
2023

ARCHITECTURE  
INTERIOR DESIGN  
LIGHTING  
FURNITURE  
INDUSTRIAL DESIGN  
GRAPHIC DESIGN  
PHOTOGRAPHY



JULIE CONWAY  
USA



CHARON KRANSEN  
USA



SAM TEHRANCHI  
CANADA



MARTIN KLAASEN  
SINGAPORE



DARIO DEMEO  
ITALY



SINI MAJURI  
FINLAND



ALEXANDER GIOIOSA  
ARGENTINA



CHRISTOPH WOOP  
GERMANY



YADOLLAH VALIZADEH  
IRAN



PEYMAN KIANI  
IRAN

more info: [award.kioskedia.com](http://award.kioskedia.com)

[kioskediaawards](https://www.instagram.com/kioskediaawards)

---

# Gold Sponsors

## Matiyar Curtain Design & Fabrics

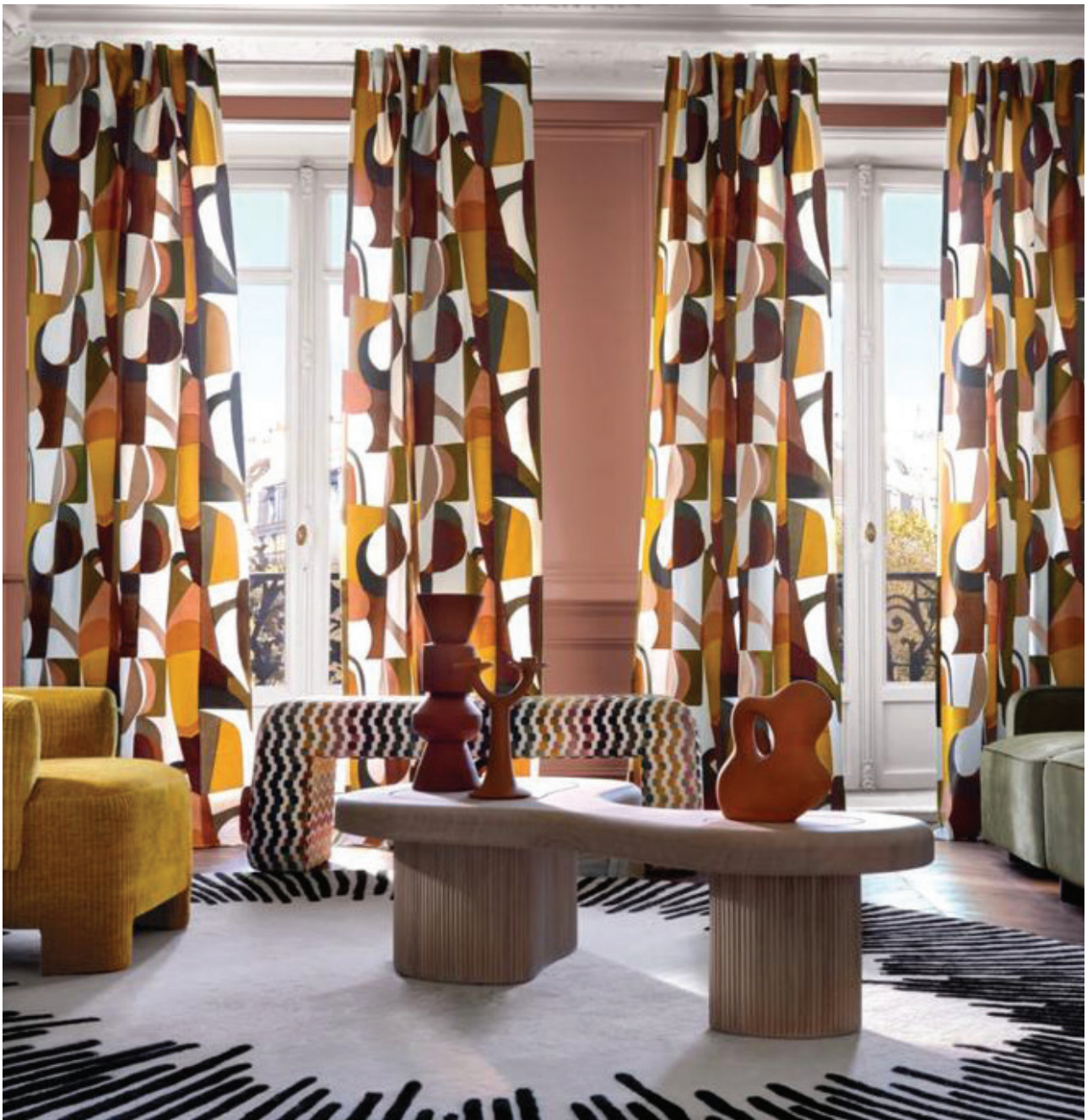



## Matiyar Curtain Design & Fabrics

The Matiyar brand offers individuals, professionals and decorators a large selection to match various international decorative styles. Matiyar furniture fabric and curtains have prepared new collections of special fabrics, with a unique design and a cultural, artistic and emotional experience to cover and beautify your entire home and even your workplace; Fabric design is derived from simple collections, printing, embroideries, ideal textures for making and designing sofas, curtains, cushions, chairs, shutters, bedspreads, etc. The Matiyar brand also offers a wide range of simple and easy fabrics, which are water-repellent and easy-care fabrics that can be used to meet the needs of restaurants and hotels. Matiyar brand tries to provide you comfort by using smart and electric materials and accessories in addition to unique design.

Website: [Matiyargallery.com](http://Matiyargallery.com)

Instagram: [matiyar\\_curtain\\_design](https://www.instagram.com/matiyar_curtain_design)

Tel: +98912-3210614



# Media Sponsor

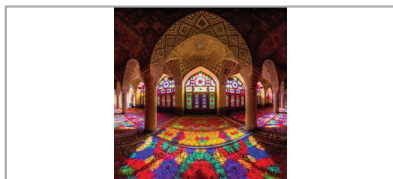
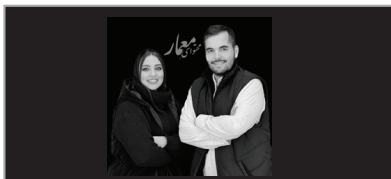

# Academic Sponsors

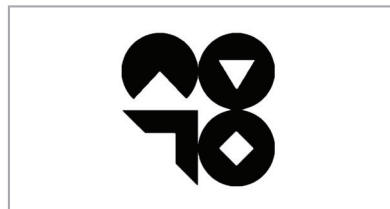

**Mains Winners**  
**of KIOSKEDIA**  
**International Design Award**  
**2023**

# Main winners

## Architecture

1st Winner

# White Bricks House



**Location of the project:** Brasilia / Brazil

**Category**

Architecture

**Year of design**

2023

**Design team**

Henrique Coutinho, Daniel Mangabeira and Matheus Seco

**Credits:**

Photos: Joana Franca

**Description:** The White Bricks House was built in an extremely artisanal way by masons-craftsmen, in a slow and precise process. Although it is a constructive process that is not very widespread in Brasilia nowadays, the use of exposed solid bricks has a constructive complexity that requires precision and constructive refinement, elements that are very present in the most representative public buildings of Brasilia. Built on a residential complex in the Lago Sul region of Brasilia, the program was distributed around the perimeter of the plot so that all the main rooms of the house could face the central area, with a large green area and a semi-Olympic lap pool. Therefore, the bedrooms, living rooms, verandas, kitchen and even the garage were directed towards the large garden environment that functions as a central patio. The facades are covered by an outer layer of solid bricks painted white. Its different degrees of openness are formed by the variable spacing between the bricks

**Website**

<http://www.bloco.arq.br>

# Main winners

## Architecture

2nd Winner

## Hesar Villa



### Location of the project

Mashhad/Iran

### Category

Architecture

### Year of design

2017

### Design team

Afshin Khosravian, Design Team: Ghazaleh Davari, Mahsa Sedaghat Sharifi, Mahnaz Dolat Abadi, Sogol Firouz, Susan Sajadian, Fatemeh Karimi, Sabereh Nikoo, Omid Sayah Graphic Design: Reza Mohtashami, Zahra Bahra

### Lead designer

Afshin Khosravian

### Credits

Photographs: Nimkat Studio, Supervisor: Vajihe Hosseyni Abrishami, General Contractor: Mohamadhoseyn Khodaverdi & associats

### Description

In Hesar Villa experience of transferring the central yard to a mountainous area was considered by the designers' team due to creating an introspective space with the intended privacy of the operators. A linear bridge that creates a good visual relation with a dominant view of the project on the one hand and the central yard, on the other hand, connects these two. The exterior swimming pool of the project is located at the center of introspective and extrospective spaces with a dual specification, on the path of the local breeze, which significantly decreases the central yard temperature.

### Website

<http://afshin-khosravian.com/>

# Main winners

## Architecture

### 3rd Winner

### Exposur



**Location of the project**  
Esfahan/Iran

**Category**  
Architecture

**Year of design**  
2021

**Design team**  
Azita Etminani Esfahani

**Credits**  
Photography: Ali Moghadam, Modeling & Graphic: Shaghayegh Bateni, Fateme Yazdan

**Description**  
The essence of this project is the infusion of opposite elements in a uniform mass which has been achieved by combining a dominant white frame, a cube with iron oxide texture, and a glass wall, creating a dynamic & delightful interior with a wide view of the garden. The south facade is where indoor & outdoor spaces are intertwined as the line between the two has been weakened via terraces that set back or extend from it. This allows for the continuation of spaces & their qualities, inside & out. Additionally, the user can continuously experience a dynamic relationship between the indoor spaces & the garden due to the combination of transparent & opaque modular cubic spaces. The design's focal point is an iron oxide cube which facilitates the vertical & horizontal access between different parts of the villa by a glass bridge and a staircase. The cube's material represents the significant effects of the environment on architecture through time with its contrasting texture and color.

**Website**  
<http://www.naghsh-engar.ir>

# Main winners

## Interior Design

### 1st Winner Baftar Dermatology Clinic



#### Location of the project

Tehran/Iran

#### Category

Interior Design

#### Year of design

2022

#### Design team

Ehsan Tavassoli, Solmaz Tatari, Nila Shahmohammadi, Amir Hossein Najimi

#### Credits

Executive Manager: Armin Shahmohammadi, Photographers: Nimkat Studio, Graphic: Neda Jahantab, Mechanical engineer: Mehdi Mehravaran

#### Description

The idea for interior design of the Baftar, a dermatology Clinic, was formed by an effort to embody the concepts related to the treatment process and the oblique reference to the mastery of the doctor. Contemplating the Vocabulary related to this field brings to mind features such as texture, layers, purification, elegance, sensitivity and flexibility. To materialize these words, physical similarities and sometimes thought-out contrasts were used in an attempt to engage the audience's sense in this limited and small spatial box. The design process commenced like the work of a doctor by peeling off the additions. The totality of space got a coherent shape with the help of mesh layer. long corridor, with the potential of the trees at the end of axis, presented an opportunity for the formation of a green frame that would increase in the spatial quality. The delicate and sensitive treatment box, which is a semi-transparent glass box, has a noticeable contrast with the rough texture of the mesh.

#### Website

<http://www.asnow.ir/about>



# Main winners

## Interior Design

### 2nd Winner Binahayat: The Aqua Gym

villa, our client wanted to convert it into a public pool. Due to the small size and area it was not possible to design a swimming pool with acceptable dimensions. the yard of the villa and the existing pool was so small , so we decided to use the pool as an aqua gym , for activities such as yoga in water , etc. Since almost all swimming pools have been designed for younger people with fun activities , this pool (where the majority of its users are older people who do relaxing activities in the water) should have had a different design approach that focuses calmness instead of excitement.

#### Problem : Natural lighting:

One of the most important challenges of this project was how to provide light when it's not possible to have a window.

The Islamic government of Iran has prohibited the existence of any windows in the indoor swimming pools (due to the nobility and visibility in the women's saas).

Since the project should done within the framework of the villa and its yard, it could not use concrete and steel structures due to the restrictions due to the urban construction rules.

As a result, finding a way to use sunlight while covering the pool without steel or concrete roof became the main priority of this project. we found the only solution in the use of a semi-transparent structure.

#### Design approach, forms:

According to the decision taken in the previous stage, and the existence of curved forms in the roof structure which



#### Location of the project

Rasht/Iran

#### Category

Interior Design

#### Year of design

2019

#### Designer

Pejman Tayebi

#### Credits

Photographer : Mahan Haji Abbas

#### Description

This project was a small pool located in the courtyard of a villa, our client wanted to convert it into a public pool. One of the challenges of this project was how to provide light when it's not possible to have a window. The Islamic government of Iran has prohibited using windows in swimming pools .we could not use concrete and steel structures due to the restrictions of urban construction rules. so, we should find a way to use sunlight while covering the pool without steel or concrete. we found the only solution in the use of a semi-transparent structure. According to the decision taken in the previous stage, and the existence of curved forms in the roof Tension Fabric Structure , designing of all parts of the project was based on curves and forms having harmony with the roof. Spaces such as the coffee shop, benches, showers, etc. all designed to work with each other. they join together and form the whole design as an aesthetic and decorative element.

# Main winners

## Interior Design

3rd Winner

Lafour



### Location of the project

Tehran/Iran

### Category

Interior Design

### Year of design

2022

### Design team

Dr.Pooran Ahmadvand , Arman yaghoobi , Amir mohamad firoozi , Ayda Pournia, Arman Nematipor , Ali Honarva

### Description

For designing this project the main focus was to represent the warmth feeling of an intimate Iranian home. Therefore we have tried to use brick as a main material of ancient Iranian homes to indicate the same feeling in this project. Since this shop is the only storefront of Hadish mall with the double volume ceiling height, we used this potential as a design strategy to create portable 3 by 3 meter cube facing towards street for displaying furniture. Beside that we designed a suspended glass roof to place furniture on top of it, so the people who come inside the shop can see the furniture from different angles.

# Main winners

## Industrial Products Design

---

1st Winner

Stalich



**Location of the project**

Tehran/Iran

**Category**

Industrial Products Design

**Year of design**

2023

**Designer**

Hasti Haj Khan Mirza Saraf

**Description**

Constellations and stars have played a significant role in timekeeping. STALICH is a wristwatch inspired by this function. The watch face is set with diamonds in the shape of constellations and the rings around the watch face are inspired by the orbits of the galaxy. The watch's unique feature is a new way of displaying the time and date using illumination. At the beginning of each new month, as the moonstone changes color, the constellation associated with that month is illuminated on the watch face. To understand the time, the light that lights up in green in the outer circuit represents the hour, and the light that lights up in red in the inner circuit represents the minute. In order to set the date and time, respectively, it is enough to press the bottom plate on the hand surface twice and the rings once until they are released with the help of a spring mechanism and return to their place by pressing again. STALICH is a watch that brings the beauty of the night sky to your wrist.

# Main winners

## Industrial Products Design

### 2nd Winner

## Bermuda Compasses

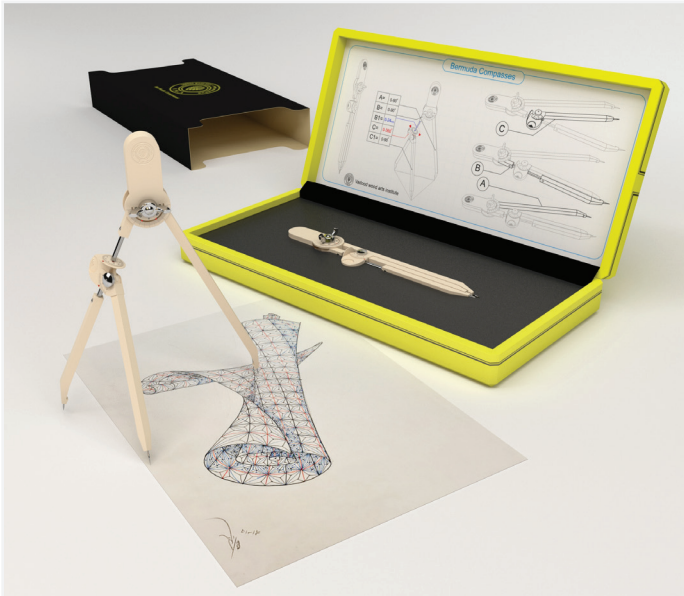

#### Location of the project

Tehran/Iran

#### Category

Industrial Products Design

#### Year of design

2023

#### Designer

Mohammadali Vadood

#### Credits

3-D Photo Designer: Sajed Afshar Pour

#### Description

“Bermuda Compasses” can be introduced as evolved drafting compasses with an addition of a third leg (C) which has the ability to rotate 360 degrees around the axis of the first leg (A) and also the possibility of simultaneous longitudinal movement on the axis of the first leg (A), so that the necessary maneuver for measuring between the three points (A, B and C) can be provided to shape a triangle. The presence of graduated plates that specify the angle from zero to ninety degrees provides recording the angle of legs A, B and C, and also the presence of a 360-degree graduated plate provides the possibility of detecting and recording the angle of leg C around the axis of leg A. Creating geometric volumes often requires complicated calculations or the use of special softwares. “Bermuda Compasses” can be used in the measurement and estimation of geometric volumes, either complicated or simple, without the need of any pre-calculations, offering more possibilities in ideation and design.

#### Website

<http://mohammadalivadood.ir>

# Main winners

## Industrial Products Design

---

3rd Winner

UoU



**Location of the project**

Tehran/Iran

**Category**

Industrial Products Design

**Year of design**

2022

**Design team**

Parsa Shaker, Shahradeh Nazarzadeh Oghaz

**Description**

This cute silicon food accessory is a simple solution to prevent wasting foodstuffs (ice-cream and popsicle). This product is designed to be placed under the ice-creams and popsicles. While children are having ice-cream or popsicles UoU will store all the leaking drops so caps can be mount and placed in the freezer to have it later. Also, we designed the surface of the UoU with cute and minimal patterns which are imprinted on the re-glaciated ice cream. Kids will love it!

# Main winners

## Lighting

1st Winner

Denge



### Location of the project

Turkey /Istanbul

### Category

Lighting

### Year of design

2018

### Designer

Merve Mehan

### Description

Balance rises from the contrast which can be seen in every corner of our planet. Defect is the reason that we exist and a noun that we can see in the creation of the universe. Light is meaningless, without darkness. And where there is perfection, there is always a defect. We believe in that concept of perfection even though we know that we will not be able to reach it. We try to reach and keep it alive. Humanity lives with defects while searching for perfection and this is the reason why we design, compose, and always look for beauty. It disrupts perfection when piercing the circle with asymmetric sticks. If being balanced means for you, your symbolic product is Denge friends. "Denge" means "balance" in Turkish. Product diameter 53cm, Height:130 cm. Painted Metal Body with LED Light

# Main winners

## Lighting

### 2nd Winner

### Bamboo

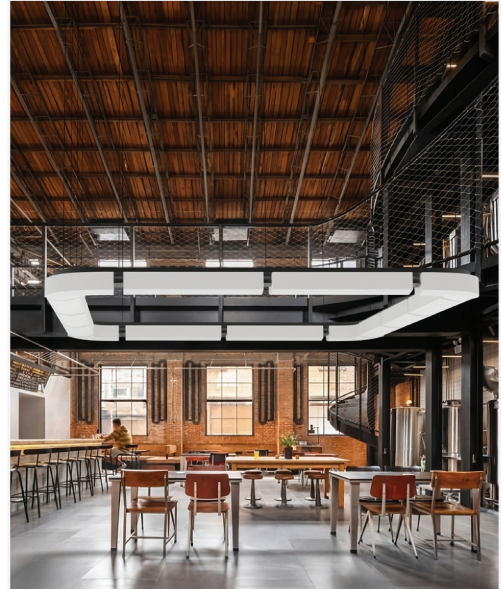
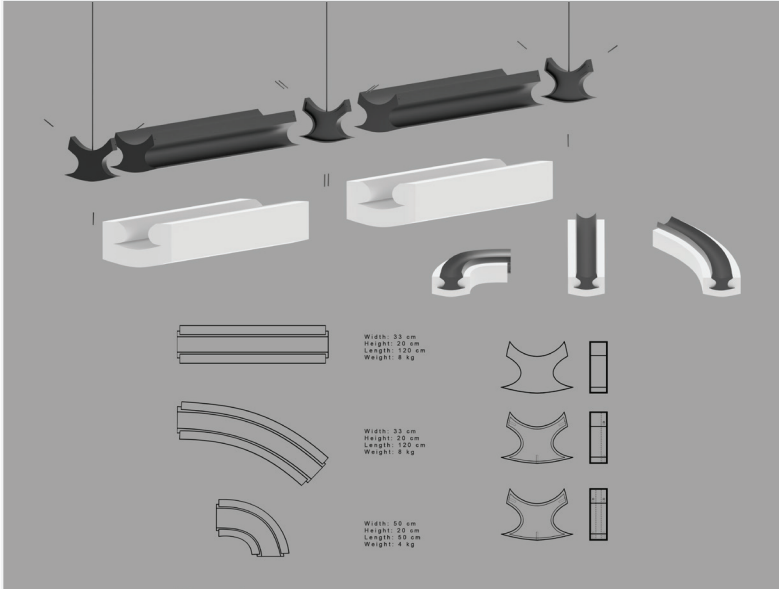

#### Location of the project

Iran

#### Category

Lighting

#### Year of design

2023

#### Designer

Roozbeh Heydari

#### Description

Bamboo is a family of lights that can be put together in different situations to fulfill their main task of providing lighting. If you pay attention to the connections between the pieces, you will notice the inspiration from the bamboo tree. The main parts of the body are black and the lights are connected to them, they are designed with the inspiration of the longitudinal cut of bamboo trees and its material is aluminum. The body of the lights is made of white plastic (polyethylene) and the light producing sources are placed inside this section. At the beginning and end of each piece of the main body, there is a connecting piece that has tasks; firstly, connecting each piece to the previous and next piece, and secondly, connecting all the components and each piece to the roof, which are made of aluminum and have a black color and they are connected to the main parts by screw connections. It has been important for bamboo to respond to modular needs in the place and space of its use.

# Main winners

## Lighting

3rd Winner

Life



TIME	product	light brightness status
7:00 PM		
7:30 PM		
8:00 PM		
11:00 PM		
5:00 AM		
5:30 AM		
6:00 AM		

### Location of the project

Iran/Mashhad

### Category

Lighting

### Year of design

2022

### Designer

Mousarreza Bashizadeh Fakhar

### Description

This wall lamp is designed in a minimal style and with a semiotic method, which plays the role of a complementary lamp or a sleeping lamp in the interior of the house in different parts of the living room and bedrooms. This smart light evokes the rising and setting of the moon when we are at the edge of the sea. The idea of this design originates from the fact that one afternoon I fell asleep before sunset and after waking up I was faced with sudden darkness, which caused me confusion and I thought about how to solve this problem, I came to this conclusion. If a soft ambient light was on in the house, it would prevent that from happening, so I designed a smart lamp that adjusts the light inside the house according to the outside light. This smart wall light rises with the sunset. And it is inspired by the sunrise and sunset and the sunrise and sunset of the moon on the horizon of the sea, which is very relaxing and nostalgic for humans and it is life.



## Main winners

### Furniture and Decorative Items

---

1st Winner

## Twisting Chair



#### Location of the project

South Korea

#### Category

Furniture and Decorative Items

#### Year of design

2021

#### Designer

Lee Daeun

#### Description

“Twisting chair” is designed with a straightforward and enjoyable assembly method. It consists of a back plate, a seat plate, and four leg parts. After interlocking the different parts of the chair, grasp the wooden rods and twist the elastic straps located on the seat plate and back plate, and insert them into the round grooves. This process enhances the overall stability of the chair, as the leg frame and plates generate tension that pulls each other together. Also, the seat plate and back plate feature small grooves through which the elastic straps pass, making the design point and enhancing comfort while sitting. The Twisting chair is convenient due to its easy disassembly, allowing individuals to move it wherever they desire. In addition, 12T birch plywood features a lightweight structure and is designed to prioritize both safety and comfort.

# Main winners

## Furniture and Decorative Items

---

2nd Winner

ODE



**Location of the project**  
Reggio Emilia / Italy

**Category**  
Furniture and Decorative Items

**Year of design**  
2020

**Designer**  
Stefano Lodesani

**Credits**  
Photography : Davide Bartolai, Pottery : Cuorecarpenito, Decorative tree : Cardo

**Description**  
Ode is a flexible shelving system, with a dual use, as a wall shelving system and as an element of spatial organization. The elements have been designed to be able to be rotated and make the shelving system extremely simple and customizable. The elements are independent, easily removable, they have no fixing elements and don't require tools for their assembly. They can be removed or added, turned or inverted, allowing infinite compositions. The extreme simplicity of the assembly procedure allow to disassemble and reassemble the shelving system as many times as you desire, adapting it to the new needs and in complete autonomy, follow the vision of eco-sustainability. For the same reason the boards have been simplified to allow customers to manufacture them autonomously, locally and choosing from the material they prefer. It is produced by Nstart srl and comes in black painted metal or natural black iron. The curved part can also be partially covered with other materials.

**Website**  
<http://www.lodesani.com>

# Main winners

## Furniture and Decorative Items

---

3rd Winner

## Speakulpture



### Location of the project

Iran

### Year of design

2023

### Category

Furniture and Decorative Items

### Design team

Parisa Eslam Shoar , Saeed Hasan Zadeh

### Credits

Photographer: Shahrouz Karimi

### Description

The project was inspired by the combination of a gramophone and dance, aiming to create a functional sculpture that amplifies sound. The inner structure of the amplifier is cone-like, while the outer structure takes inspiration from movement and dance, resulting in a dynamic form. To use the amplifier, simply place your smartphone in its holder and play music. The gradual increase of the horn-like shape prevents distortion, magnifies the sound, and projects clear and loud music towards the listener. When not in use, it serves as an aesthetically pleasing decor piece. The main materials used to create this eco-friendly product are waste paper and water-based resin. Despite these sustainable materials, the amplifier has a smooth and polished finish. It does not require any electrical power source, making it a functional audio equipment that can be used anywhere. "Speakulpture" is a product that combines artistry, functionality, and sentimental value.

## Main winners

### Photography and creating photo collages

---

1st Winner

## Shrine of Hearts



#### Location of the project

Ardabil/Iran

#### Category

Photography and creating photo collages

#### Year of design

2020

#### By

Behnam Khoshbaten

#### Description

The tomb of Sheikh Safi in Ardabil is one of the places where being in that space inspires a special peace and in terms of architecture, it is one of the most beautiful works based on Eastern mysticism. In this photo, I tried to record a different panorama of the courtyard of this complex to show the spiritual wheel and the flight of the human spirit in that space. This image consists of 36 pieces of photos and the sky and the moon were recorded separately on the same day.

## Main winners

### Photography and creating photo collages

---

#### 2nd Winner

#### Comrade



**Location of the project**  
Iran

**Year of design**  
2021

**Category**  
Photography and creating photo collages

**By**  
Hasan Nazari

**Description**

The only friend he had was the dog, he had no home and lived under an abandoned bridge. What attracted me to photography was the intimacy between Mojtabi and this dog. Mojtaba's face shape and eyes have a lot to say. Canon 760D camera with 85 mm fixed lens and a portable light branch was used to take this photo.

## Main winners

### Photography and creating photo collages

---

3rd Winner

## The Blue Eye



#### Location of the project

Hamedan/Iran

#### Category

Photography and creating photo collages

#### Year of design

2020

#### By

Shahin Khalaji

#### Credits

Shahin Khalaji

#### Description

This photo is inspired by professional film music by Ennio Morricone And this work is very valuable to me and has won awards in many festivals Because this music was very influential for me in my life I tried my best to capture this picture with my inner feeling Editor Sara Tahmurthy Model: Sarina Studio: 3D Director and photographer: Shahin Khalaji

# Main winners

Graphic Design and Visual Communication Communication

---

## 1st Winner Film / Theater Poster



### Location of the project

Tehran/Iran

### Category

Graphic Design and Visual Communication

### Year of design

2022

### Designer

Dariush Allahyari

### Credits

Dariush Allahyari

### Description

In my designs, I mostly work with expressionism and abstract design methods, and combining montage images is also part of my work. Of course, I also consider the customer's taste. Because the customer is considered a part of the custom work. In fact, I think more about presenting a new type of composition and atmosphere so that the works will delight me at the first glance. Of course, I know that it is a very difficult task.

# Main winners

## Graphic Design and Visual

2nd Winner

Rumi



### Location of the project

Washington/USA

### Category

Graphic Design and Visual Communication

### Year of design

2023

### Design team

Mohammad khademi , Atefe Sianat

### Description

The Rumi Carpet brand, located in the central office in America, requested our team to create a program that could not only preserve the authenticity of the product but also establish an identity that would connect with the audience. Our team made efforts to maintain this authenticity by using a name and element that reflects the historical and artistic nature of carpets. These factors were to be innovatively incorporated into the branding, showcasing beauty, simplicity, effectiveness, persuasiveness, and strategic elements. Among the historical options, the choice fell on Maulana Jalaluddin Rumi, and among the visual identities, the Sema dance was selected. This choice not only refers to the historical identity of carpets but also alludes to a historical and global figure that is also Iranian (the birthplace of carpets).



# Main winners

## Graphic Design and Visual

3rd Winner

# Kamak



**Location of the project**  
Yazd/Iran

**Category**  
Graphic Design and Visual Communication

**Year of design**  
2023

**Design team**  
Mehdi Hasan Zadeh, Mojtaba Hosseini

**Description**  
KAMAK means a small wish, a wish that started with the symbol of a dandelion. Dandelion is made up of a hundred small dandelions, and when it is in the wind, each of the dandelions will fly and follow their small dreams. One of the Dandelions is looking for a dream that he wants to find himself in a cozy cafe with a different taste of coffee to start his story with KAMAK and achieve a big dream. KAMAK, small wish

**Honorable Mentions**  
**of KIOSKEDIA**  
**International Design Award**  
**2023**

# Honorable mentions

## Architecture

### Afra



**Location of the project**  
Mashhad/Iran

**Category**  
Architecture

**Year of design**  
2020

**Design team**  
Mohamad Reyhani , Alireza Modarresi , Ali Soveizi

**Credits**  
Hamideh Sarafian, Faezeh Samadi, Matineh Rezaie, Elham Mahdian, Mohamadhossein Haji Ahmadi, Bahar Hajzadeh

**Description**  
In this project, an attempt has been made to provide the most accurate response to the surrounding environment along with the highest feedback in interaction with the surrounding events for the residents. Considering its location and nobility from the main boulevard, it should provide a city view on one side and peace and privacy on the other side for its residents. At first glance, the fluidity of the form transforms the regular and modular system into a living being that can move, walk, take shape, and at the same time beautify with maximum harmony with the chaotic environment around it, and as it sits in its place and with its ancient neighbors. They should turn their heads towards the street while talking and look at the passers-by and it will remain in their memories.

# Honorable mentions

## Architecture

### Avangan Villa



**Location of the project**  
Kordan/Alborz/Iran

**Category**  
Architecture

**Year of design**  
2023

**Design team**  
Ramin Rahmani, Farima Shahbazi Matin, Armita Abasi

#### **Description**

This two-story villa with a size of 500 square meters is designed in a garden with a size of 1580 square meters in the city of Kordan Karaj. The critical feature of this villa is the active and suspended ceiling scattered in the garden. By increasing the thickness of the ceiling, common spaces including stairwells and elevators have been placed. The movement of the ceiling downwards has shaped spaces such as bedrooms, living rooms, and the project's main goals. Other main spaces on the ground floor, including the kitchen and living room, are formed in line with the garden and between the hanging boxes.

# Honorable mentions

## Architecture

### Bagh Chal Khane



#### Location of the project

Tabas/Iran

#### Category

Architecture

#### Year of design

2021

#### Designer

Javad Davoodi

#### Credits

2D: Saeed Mohajeri , Sara Mohajeri / 3D: Pouya Ahmadi / Render: Hosein Sadeghi/

#### Description

Baghchal Khaneh, in Tabas, a city located in desert, is designed with an Iranian architectural approach in hot and dry climates. Using garden pit is the main concept of the project due to the climatic conditions, which are located on the negative floor. The central yard is one of the main pillars of Iranian architecture in hot and dry climates. The pool in the central yard is used to provide humidity and control the heat intensity and... The material of bricks and clay that is the use of eco-friendly materials in that climate. The heat capacity of bricks in cold nights and hot days of the desert, due to saving heat and its transfer to inside of the house during the night, seems to be a suitable climatic factor. On the other hand, hollow bricks do not act well in absorbing and transferring heat over time and act as better insulators. The porch is the semi-open space of this project, which plays an important role in making a desirable life at the house.

# Honorable mentions

## Architecture

### Family Villa



**Location of the project**  
Mazandaran/Iran

**Category**  
Architecture

**Year of design**  
2020

**Design team**  
Touraj Omran, Jaber Hosseini, Haniye Gholizadeh, Fatemeh Hendoyi

**Credits**  
Photographer : Benjamin JahanShahi

#### **Description**

A project with an area of 1000 square meters was entrusted to our design team with our suggestion to build a villa with an area of 350 square meters. One of the main design challenges for us was designing a privacy zone for this family, which also affected the design concept. In this way, the project was located in a stepped form so that, in addition to not disturbing the view of the neighboring villa, it also creates a privacy zone. The considered principle in designing this suburban villa is to create spatial qualities in order to provide dynamic features for the elements. In this project, the relationship between the structure of the building and the light conditions and environmental conditions have been carefully designed and these conditions work in contrast to each other and give meaning to the structure of the building in direct relationship with the climate.

# Honorable mentions

## Architecture

### Kaaraamiaan

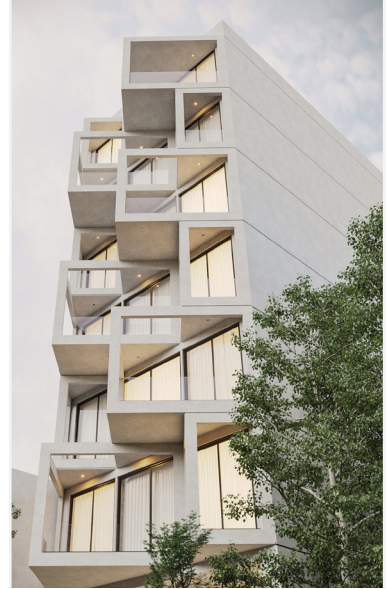

#### Location of the project

Tehran/Iran

#### Category

Architecture

#### Year of design

2022

#### Designer

Amir Shojaeian

#### Credits

CG Artist: Behnam Sari

#### Description

The Kaaraamiaan building is located in an alley with a narrow passage and among neighbors who have a long history and friendship with each other. It was important for us to respect the other license plates and the pedestrians of this passage, so that this building can be seen in the same way from both sides of the alley in this narrow passage. Kaaraamiaan building consists of six residential floors, ground floor and three negative floors, with half-floor parking and residential units including three southern duplex units and two northern flat units. The type of arrangement of spaces and options of the building such as personal library, maid's room on the floors and other spaces were according to the personal needs of the client.

# Honorable mentions

## Architecture

### Levitation

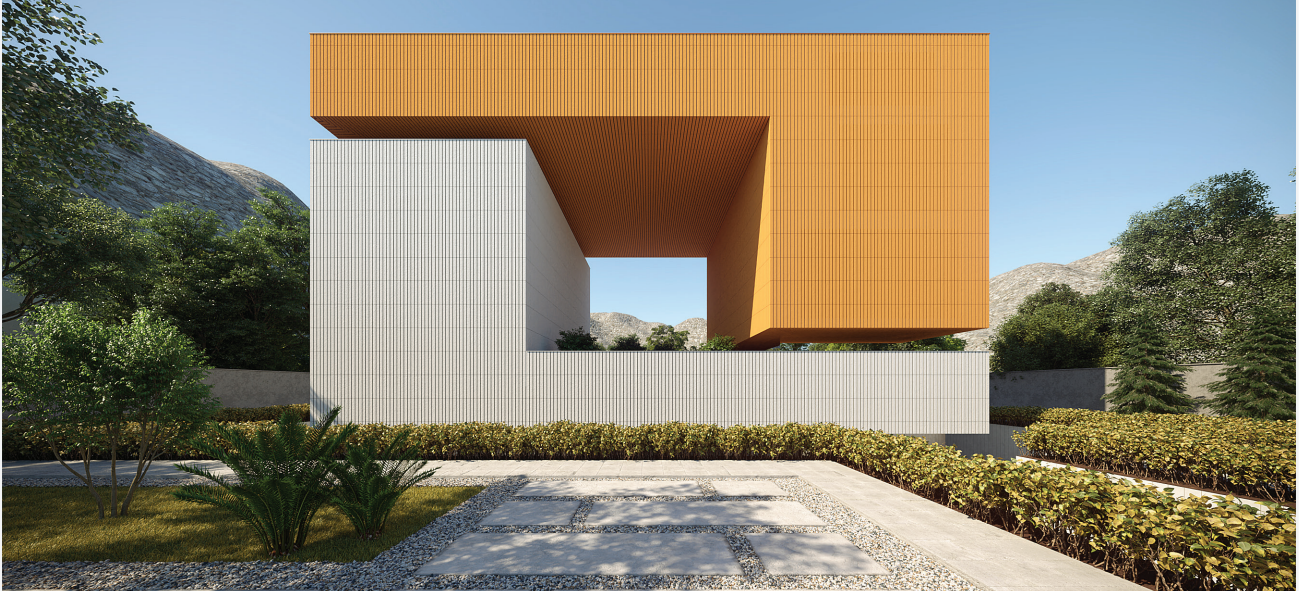

**Location of the project**  
Kerman/Iran

**Category**  
Architecture

**Year of design**  
2023

**Design team**  
Kaveh Amini, Saeed Deylaghian, Fatemeh Salmani, Mohsen Hashtadani, Elaheh Ramezan zadeh, Mehrad Afrash

**Description**  
This project is about merging independence with unity. two villa units for a father and son come together like two hands want to shake and both of the units look levitated and floating in the air as a result of using mirrored steel sheets in the gaps and The Root.all you need to know is written in pdf sheet.



# Honorable mentions

## Architecture

### National Institute of Fine Arts



#### Location of the project

Rajasthan/India

#### Category

Architecture

#### Year of design

2022

#### Designer

Anamika Tiwari

#### Description

The idea is to design a building that can be perceived differently in each zone. The spaces can be experienced with different perceptions throughout the day that will be generated due to the light and the absence of light. To incorporate the idea into the built form, The stepwell of Rajsthan has been taken as the inspiration, which also reflects the culture and traditional architectural style of Rajsthan. The Stepwell has its own generated patterns of lights and shadows, and it also creates space to sit, interact, or study (In the case of an Institute).

# Honorable mentions

## Architecture

### The Belvedere For A Flaneur



**Location of the project**  
Sari/Iran

**Category**  
Architecture

**Year of design**  
2023

**Design team**  
Morteza Nikfetrat, Arvin Tavakolinia , Mohammad Soleimani Saber , Seyed Hamed Hajimirzade

#### **Description**

Nefaar is a single-room building that is located a few meters above the ground. The open area of the room allows its residents to use adequate ventilation and breeze. And also watch the fundamental changes in the surrounding landscapes in different seasons. Regardless of physical and material qualities, Nefaar shows man's vision of existence and provides a possibility for him to deepen his mental ideas. With the change of the seasons and the change of the environment, Nefaar forces the thought of man to change. The idea of this design was formed from the text written by Henry David Thoreau in the book of Walden, and we considered it for a Flaneur. In a specific season of our life, we get used to considering every corner as land to build a house. It was like this that I imagined every corner of a vast plain as a place for a mansion. In my imagination, I imagined the fields in front of my house.

# Honorable mentions

## Architecture

### Villa Ashian



#### Location of the project

Damavand/Tehran/Iran

#### Category

Architecture

#### Year of design

2020

#### Design team

Mahdi Alambeigi, Atlant's Team

#### Credits

Photographer : Mohamadhosein Hamzeluoi

#### Description

The Ashian Villa project is situated on an island-like plot with access from four directions to the street path, nestled in the foothills of Ayneh Varzan in the Damavand suburb. Our most significant challenge in this project was the site's limitations due to the asymmetrical form of the walls and the land's considerable slope. To tackle this, we started the design project by defining a scenario that included site analysis, client requests, the architectural team's conceptual ideas, and overarching rules. The client's primary requests were for the building to be a landmark in the local context and to make optimal use of the site. The conditions and limitations of the land were among the most influential factors in this process, which we thoroughly examined.

#### Website

<http://atlantarchitects.com>

# Honorable mentions

## Architecture

### Villa No.99

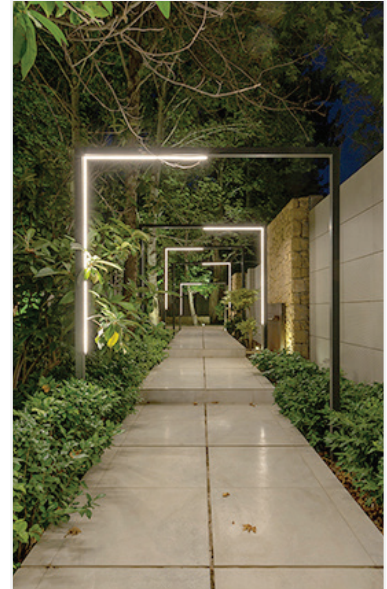

**Location of the project**  
Shiraz/Iran

**Category**  
Architecture

**Year of design**  
2022

**Designer**  
Hossein shahdi

**Credits**  
photographer:Arash Akhtaran. Editor:Najmeh Karimi

#### **Description**

The villa has been designed in a garden with old trees without damaging even a single tree.the designer decided to place the villa in a continuous volume in the body of the garden and between the trees in such a way that the border between all the spaces and the green space outside is minimized.The use of metal with rust has been done in such a way that in a moment of history, time has stopped and these metals have remained in the same form at that moment forever. The designer's effort in designing and making these volumes as well as doors, handles and locks, chandeliers, barbecues, sinks and faucets in the outdoor space using rusted metals but with a different and mechanical approach as independent members added to the body of the garden. It has created a subtle and sweet contradiction in the mind of the audience as if these bodies and bodies, despite their inherent strength and solidity, have taken refuge in the lap of the garden and its ancient nature and are even trying to serve it.

# Honorable mentions

## Interior Design

### A.B Studio



**Location of the project**  
Shiraz/Iran

**Category**  
Interior Design

**Year of design**  
2018

**Designer**  
Ali Bazmandegan

#### **Description**

Vision: The A.B Art Studio was brought to life to provide a space where art is born. It transcends being just a physical space; but a sanctuary where the creative process thrives. The studio extends its invitation to aspiring artists, art students, and anyone interested in the realm of creativity. Location: Perched before the majestic Shiraz Quran Gate and overlooking the mountains, the A.B Studio's atmosphere exudes both serenity and vitality. A bustling street between the studio and the mountain maintains a dynamic energy. Architectural Integration: The studio's architecture is a tribute to native aesthetics and simplicity. What was once a six-bay shop has transformed into a harmonious space that celebrates the basics. Call to the Senses: When the studio's windows embrace the street and mountain, sunlight spills onto the cement floor. The rhythm of passing cars and the play of light foster a sensory experience that elevates creativity.

# Honorable mentions

## Interior Design

### Aysan



**Location of the project**  
Shiraz/Iran

**Category**  
Interior Design

**Year of design**  
2022

**Design team**  
Mojtaba Hooshangian Shirazi, Hilda Khozae nezhad

**Credits**  
Presentation: Hilda Khozae nezhad, Saedeh Mohamadi--- Executive Team: Iman Gharehkhania, Maryam Nazari--  
Photographer: Navid Atrvash

#### **Description**

This showroom is located in the basement of a building with an area of 400 square meters. In design, it was tried to create the depth of the field and encourage the audience to follow their discoveries in space. To separate the space, instead of using partitions, two-sided folded plates were used to divide the space which were connected from one point and not from one side. The furniture and especially the bed set made it possible for the designer to cut the space in the third dimension by using an imaginary line at the level of 120 cm. and place a part of the separating plates above the hypothetical line of sight and the other part below the 120 cm level. That this movement creates spaces that were full and empty together. To create a sense of suspense in the space, 90% of common points in the composition of the pages were combined through a single point instead of being considered as a line. The lighting of the space was also formed in the direction of the sense of suspense.

**Website**  
<https://mo-shir.com/>

# Honorable mentions

## Interior Design

### CoDA Headquarters



#### Location of the project

Brasilia/Brazil

#### Category

Interior Design

#### Year of design

2023

#### Design team

Pedro Grilo, Gabriel Goes

#### Credits

Construction Supervision: Rafferson Camel, Photography: Julia Totoli, Executive project: Carolina Piana, Julia Coutinho and Gabriel Moreira

#### Description

The office for an architecture practice is located in a 70's brutalist building by architect Joao Filgueiras Lima. It's located at a central area of Brasilia, Brazil, that lost attention in the late-90s but has been facing a revitalization. The building itself is almost completely built in precast concrete - with modular slabs, walls, facades and even precast windows. The office's interior thus emphasizes its original features, its modular layout and, apparent electrical installations and concrete. Seeking simplicity, the 990 sq ft space was divided by four, its program composed of the team's workspace, a meeting room, a small office kitchen and a server room. The overall materiality was based on the building's preexisting elements: white fiber panels, concrete and its iconic orange brise-soleils. So, white is a predominant color, along with the terracota tone flooring and kitchen tiles. The decor blends vintage and contemporary, with mostly wooden furniture by brazilian designers.

#### Website

<https://www.coda.com.br/>

# Honorable mentions

## Interior Design

### Ehsan's flat

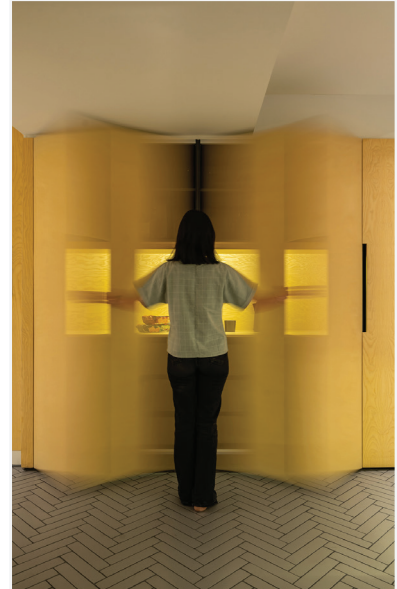

#### Location of the project

Shiraz/Iran

#### Category

Interior Design

#### Year of design

2022

#### Design team

Mojtaba Hooshangian Shirazi, Sina Safari

#### Credits

Presentation: Sina Safari, Sogand Abroshan , Executive Team: Masoud Hooshangian Shirazi, Poran Kazemi

#### Description

Ehsan's flat is a suite with an area of 95square meters. The design of this project started for a young couple. Most of our lives have a two-sided edge, we don't need these boundaries on one edge, and at the same time, removing these separations will cause us problems in the long run. So we need spaces that are flexible and we can change them according to our needs. In the concept of this project, a private space was created that can be removed and allows the young couple to enjoy a flat without a separator on a daily basis, and the same flat allows them to maintain privacy during a party. The main idea in spatial separation in this suite is the possibility of merging and separating public and private spaces to meet the client's needs. The main element in meeting this need is a wooden rail door in the middle of the project. These openings can be hidden behind their side walls and do not have a visual impact on the space when they are open and do not occupy additional space.

#### Website

<https://mo-shir.com/>



# Honorable mentions

## Interior Design

### Nirvana Rock Cafe



#### Location of the project

Mazandaran/Iran

#### Category

Interior Design

#### Year of design

2022

#### Design team

Navid Arjmandi, Motahareh Taheri, Niloufar Hossein pur

#### Credits

Armin Rezvani

#### Description

As the name suggests, Nirvana Rock Cafe Project is a coffee Shop focusing on rock music. In addition to the warm and calm atmosphere of a Cafe, the goals of this project are to consider things such as the privacy of the interior space, to pay special attention to conveying the feeling of rock music, and also to provide a space for the performance of music groups with different styles. In the facade part of the project, an attempt was made to preserve the privacy of the interior space and also create a corridor for the entrance by creating a non-opening screen for the upper part of the facade, which creates an inviting feeling for the entrance part. In the interior part, the design was developed in such a way that there is a proper connection between the service spaces and the sitting areas to facilitate the customers and attendants commutes as much as possible.

# Honorable mentions

## Interior Design

### Moshir



**Location of the project**  
Shiraz/Iran

**Category**  
Interior Design

**Year of design**  
2022

**Design team**  
Mojtaba Hooshangian Shirazi, Mahsa Pakshir

**Credits**  
3D modeling: Mahsa Pakshir, Presentation: Mahsa Pakshir, Kiana Nourizadeh , Executive Team: Sara khoramKhorshid, Ali Saeyan, Mahsa pakshir

**Description**  
In this project, the first objective of the architecture was to place functions that should be on one level on two levels in such a way that the acoustic and physical communication, and eventually the functionality of separate components, are not disrupted. It was chosen to construct a communication shaft that brings light to the ground floor. the people who entered the second-floor studio, go through the office manager's filter. also the location of the architecture studio needs to have good views and adequate lighting. With two objectives in mind, the facade concept was created. First, the office block should set itself apart from the windows and restrictions of residential facades in the setting of the nearby residential buildings. Second, it shouldn't tear apart the character of a community that is more than 50 years old. This office's objectives are to build a home where architecture is built. Moreover, it is still a long way from commercially active offices with a large clientele.

**Website**  
<https://mo-shir.com/>

# Honorable mentions

## Interior Design

### Peydaye Penhan



#### Location of the project

Isfahan/Iran

#### Category

Interior Design

#### Year of design

2020

#### Designer

Mandana Keihanfar

#### Credits

Photographer: Studiio47

#### Description

PEYDAYE PENHAN means hidden visible. the client's demand is to create an intimate and small space at the same time has its own separate privacy and economically. The design was based on the creation of two different zones, which were later called guest and host spaces, as well as observing the characteristics of modern architecture, in order to attract the attention of the young client. The host and guest zone is sewn together by the expose stair and the elemental staircase is an indicator in the design of this space and in the vicinity of the skewed elements, which creates a hidden find from the narrow and stretched windows. As a result, the view of this space has a controlled view of the guest space and vice versa, and responds to the client's goal of creating a cozy atmosphere.

# Honorable mentions

## Interior Design

### Porch



#### Location of the project

Tehran/Iran

#### Category

Interior Design

#### Year of design

2023

#### Designer

Salva Abed

#### Credits

Design and Implementation Support: Mahyar Haji Mohammadreza, Negin Teymouri, Photographer: Milad karimian, Siavash Bagheri

#### Description

Porch is a multifunction building which makes it an attractive and challenging project for us, The organizational colors of this brand are blue and grey, so these colors are vividly implemented in the design. Porch is a three stories villa house that has multifunctional working spaces of different sectors. Engineering, design, manufacturing of furniture, installation and etc. have been executed within 6 months. All the furniture and wooden objects and segments of this project have been personalized by using curved lines to harmonize with the old structure of this magnificent -building. Enclosed are pictures of the sales gallery, trading room, watch and jeweler room, hallway and management room respectively.

# Honorable mentions

## Interior Design

### Shirin House

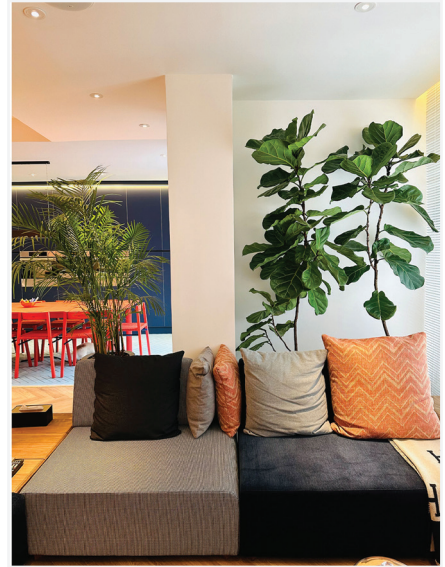

#### Location of the project

Tehran/Iran

#### Category

Industrial Products Design

#### Year of design

2023

#### Design team

Navid Barzarian, Omid Barzarian

#### Description

The “sweet house” was an offered design and furniture proposal.” for a young couple residing in the picturesque mountainous region of Niavaran, Tehran. After years of living abroad, they chose to return to Iran, yearning to relive their cherished childhood memories and recapture the nostalgic image they held of their homeland during those formative years. Drawing inspiration from this rich background, the design process commenced with a strong focus on two key elements. Firstly, we placed great importance on the artful coloring of the spaces, a prominent feature in the interior architecture of historic Iranian buildings. Secondly, we embraced the utilization of cost-effective Iranian materials and accessories, skillfully designed by Iranian artists and expertly crafted in local factories. The result is a delightful Persian home that evokes a sense of childlike wonder, harmoniously combining feelings of tranquility and exhilaration.

# Honorable mentions

## Interior Design

### Sakkou Ventures



#### Location of the project

Iran

#### Category

Interior Design

#### Design team

Amir Nikdel, Design Partners: Shadi Maleki , Aida Rastegar , Roja Chehreh Interior Design and Architecture: Nikdel Design Studio | NDS Conductor: Nikdel Design Studio | NDS

#### Credits

Credits: Mohammad Hossein Hamzehlouei, Shahin Namdar, Kosar Bashtani

#### Lead designer

Amir Nikdel

#### Description

“The Sakoo administrative project focused on aligning the brand’s values within startup culture. We creatively designed the space, emphasizing a youthful, dynamic atmosphere. The goal was to foster knowledge exchange and interaction within the workspace while maintaining each subsidiary’s identity. The project involved reconstructing two units within Fanap’s administrative building, distinct from its traditional mindset. The design incorporated Sakoo’s archetypes, ‘Explorer’ and ‘Ruling Hero,’ to promote connectivity and collaboration. The spiral pathway symbolized the brand’s supportive role and adventurous spirit, reflecting the brand’s primary color, blue. A uniform, quality space was created on the third floor, fostering interaction between employees and managers, embodying Sakoo’s ethos of turning dreams into reality.”

# Honorable mentions

## Industrial Products Design

---

### BBQ



#### Location of the project

Iran

#### Category

Industrial Products Design

#### Year of design

2015

#### Designer

Saeid Niakan

#### Description

In 2015, I started designing barbecues made with wood. The slogan of my work was that fire reminds you of distances. If you get too close you will burn and if you go too far you won't get warm. For me, this slogan had a social meaning in emotional relationships. During one year, I designed 23 functional barbecues that were made with two or four shovel handles and two Istanbul pieces. The reason why I used two Istanbul numbers was that the main body was double-walled to protect the wood and the handwork from heat. This grill has a mesh-shaped ball in which we pour vegetables and whatever we want to grill, and it starts rotating manually or automatically with a DC motor with RPM 5, and as it slowly It rotates, all its contents are golden and the core is cooked.

# Honorable mentions

## Industrial Products Design

### Children's Air purifier (Atmospher)



**Location of the project**  
Isfahan/Iran

**Category**  
Industrial Products Design

**Year of design**  
2022

**Design team**  
Seyed Sasan Mousavi, Mahsa Ghasemi

#### **Description**

The child's air purifier is designed in the same form as an astronaut, the features of this design are as follows: Air purification. Children's room lighting. Having a speaker to introduce galaxies and planets along with playing music. Beautiful form. User interface suitable for children. Having a filter to absorb pollution. Fixed and portable sample.



# Honorable mentions

## Industrial Products Design

---

### Ergonomic

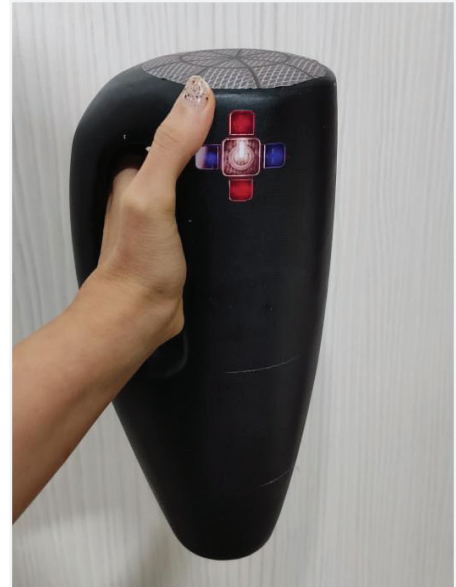

**Location of the project**  
Isfahan/Iran

**Category**  
Industrial Products Design

**Year of design**  
2023

**Design team**  
Leila Mohammadian, Mehdi Sharifian

**Credits**  
Rendering: Mehdi Sharifian, Supervisor: Dr. Mohammad Sadegh Sohrabi

**Description**  
The hairdryer is one of the essential tools for hairstylists, which they use for a significant amount of time. This open redesign project aims to improve the health, performance, comfort, and overall satisfaction of hairstylists by utilizing anthropometric data and ergonomic factors in the redesign of hairdryers.

# Honorable mentions

## Industrial Products Design

---

### Ferno

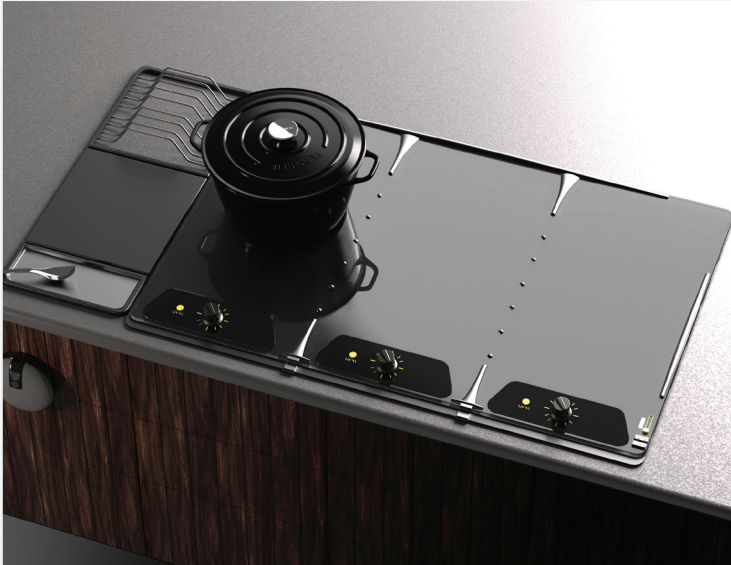

#### Location of the project

Tehran/ Iran

#### Category

Industrial Products Design

#### Year of design

2022

#### Design team

Erfan Moieni Jazani, Parsa Shaker, Shahrads Nazarzadeh Oghaz

#### Description

Ferno - A stove for Visually Impaired people The blind and visually impaired have many problems in their daily life, and most of these problems are caused by incompatibility using products used daily by most people, on the other hand, they cannot do their daily activities independently, including cooking. It made us think about the design of a minimal desktop stove example for these people. In the design of this hob, as much as possible, most of the problems of blind people while working with stoves have been considered, and as a result of work, by conducting field research, observations and interviews, it has been tried to achieve the closest result to the ideal state.

# Honorable mentions

## Industrial Products Design

### Genesis



#### Location of the project

Yazd/Iran

#### Category

Industrial Products Design

#### Year of design

2023

#### Designer

Mahdi Saryazdi

#### Description

Genesis intelligent body analyzer with a beautiful and unique design gives a checkup of different parts of the body in the most accurate way possible. One of the challenges of designing this device was its four different parts and their connection point, which in this design has a better gestalt and harmony by creating the same formal language. Compared to other similar models, the proportions of the device have been modified to have better balance and beauty. Also, the use of metal material next to plastic has given the device more strength and beauty. The angle of the monitor can be adjusted, and for transporting the device, the column of the product is designed in a movable manner, and by pressing the button next to it, the lock is released and allows it to be lowered. The three-joint handles provide 360-degree rotation, which is compatible with the ergonomics of different people's bodies, and the light under the lower surface layer gives the user a light feeling and a better experience.

# Honorable mentions

## Industrial Products Design

### Havzhin

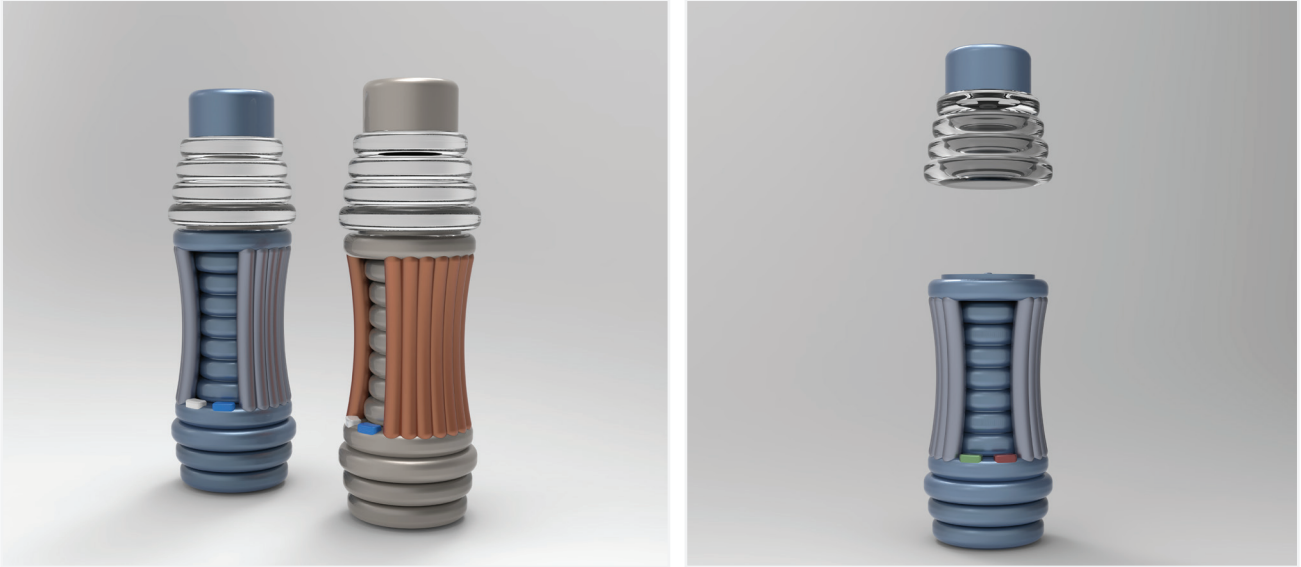

#### Location of the project

Iran

#### Category

Industrial Products Design

#### Year of design

2023

#### Design team

Moein Khaledi, Sania Rezazadegan

#### Description

Today, we see problems for parents regarding the storage, transportation and production of powdered milk, and of course reducing and optimizing the temperature of hot water solution and powdered milk for children and babies. The solution to all these problems can be found in "Havzhin" Store powdered milk and hot water separately in the surrounding compartments with the least hassle and make it easy to carry. Its lower compartment is also a place to combine hot water with powdered milk. Where after pressing the special buttons of each of the powdered milk and hot water compartments, a certain amount of each will enter this compartment and by shaking it, we will combine them completely. After that, by rotating 180 degrees around the vertically axis, the solution enters the gradual cooling process which is located in the center of it and will make the temperature of the solution suitable for the baby's use, and at the end of the way, it will enter the main milk bottle for the baby's consumption.

# Honorable mentions

## Industrial Products Design

---

### Mystic Midnight



**Location of the project**  
Toronto, Canada

**Category**  
Industrial Products Design

**Designer**  
Maryam Kordahmadi

**Description**  
This is a stunning piece of jewelry inspired by the rare and exotic black orchid flower. The black orchid flowers are crafted from onyx and diamonds, symbolizing the flower's mysterious and alluring qualities. The middle of each flower has a pear-cut emerald, signifying the flower's rarity and value. This necklace celebrates the natural world's beauty and wonder, reminding us that even the most delicate things can possess great strength and resilience. This necklace is perfect for those seeking a unique and breathtaking piece of jewelry that symbolizes beauty, strength, and resilience.

# Honorable mentions

## Industrial Products Design

### RAD



**Location of the project**  
Shiraz/Iran

**Category**  
Industrial Products Design

**Year of design**  
2022

**Design team**  
Afsoon Hoseinzadeh, Ehsan Varzandiyan

#### **Description**

The design and construction of the Rad watch was formed by AF DESIGN team which after its 3D modeling, we built it. Rad watch is made with metal body and oven paint. the design of RAD is inspired by water turbines shape. the product is made of very small and large pieces that are connected together . the watch face is quite simple, which doubles its beauty. the main body is an inspiration of water turbines shape. to replace the battery , simply unscrew the base and body screws to access the motor and watch battery. All components of the product can be separated and you can easily reconnect all parts. Dimensions of this product (20\*13\*11 cm) is Designed based on suitable dimensions for a desktop watch.

**Website**  
<http://www.afdesigning.com>

# Honorable mentions

## Industrial Products Design

### Bloomy



#### Location of the project

Tehran/Iran

#### Category

Industrial Products Design

#### Year of design

2023

#### Design team

Reza Ali Ahmadi, Amir Hossein Keshavarz, Omid Zandi

#### Description

Bloomy is a sunflower seed packaging. The design of this packaging is inspired by the sunflower and consists of two parts, the bottom part for seeds and the top one for collecting sunflower seed hulls, which blooms like a sunflower. This packaging aims to preserve the environment through green design, which is accomplished using two methods: 1) The packaging is made of cellulose and is biodegradable, posing no threat to living species. 2) The most important advantage of this packaging is that there is a separate space for the sunflower seed hulls that prevents them from spreading in urban and environmental spaces. The packaging template is easy to assemble without any special tools or knowledge. Additionally, this packaging is Glueless..

# Honorable mentions

## Industrial Products Design

### Soniclean



#### Location of the project

Tehran/Iran

#### Category

Industrial Products Design

#### Year of design

2023

#### Design team

Amir Hossein Keshavarz, Omid Zandi, Reza Ali Ahmadi

#### Description

Brush is the primary tool for painters to create their art. Cleaning paint-stained brushes is a challenge for painters. This problem can affect the quality of their work, therefore, many of painters look for better ways to wash their brushes. Even Good brushes can get damaged if they are not washed properly. Our project aims to address this issue by offering a product called The Brush washer. This product consists of an ultrasonic tank that is filled with solvent and automatically cleans the brush from the paint without requiring any special expertise, and this task is done with the least amount of damage to the brush in an acceptable time. This product is designed considering the principles of green design and it aims to reduce the use of solvents and promote sustainability. Additionally, the washing process is completely automated and does not require any user intervention. As a result, users do not come into direct contact with solvent, minimizing potential risks to human health.



# Honorable mentions

## Lighting

### Moon

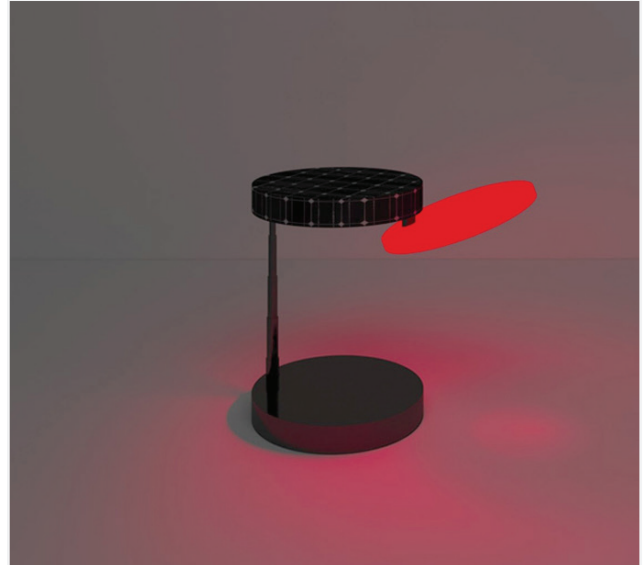

**Location of the project**  
Tehran/Iran

**Category**  
Lighting

**Year of design**  
2023

**Designer**  
Mandana Keyhanfar

**Credits**  
CG Artist: Mahsa Rafie

#### Description

This is an adjustable lighting in the category of table and portable lamp and because of its adjustable mechanism it can be used even middle of desert. we know that the moon mainly gets its light from the sun and now in this design light can be charged through solar cells. It is as if the moon appears from the darkness of the night and the design inspired of that Natural Phenomenon. It is designed in a way that is portable and multiuse. its a lighting and wireless charger too. Wires cable are passed through telescopic casing and there is a hinge That let disk to rotate and pull out the lighting segment. This light is equipped with Bluetooth Qi wireless system and solar cells as well, so its self charging and as a result its energy saving and nature lover. In addition The body material is recycled aluminum and anti scratch. Its sync with mobile application and tv so that user can change the color and adjust the intensity of light.

# Honorable mentions

## Lighting

### Circular Chandelier



**Location of the project**  
Tehran/Iran

**Category**  
Lighting

**Year of design**  
2023

**Design team**  
Afshin Mehdizadegan Hosseini, Ali Mehdizadegan Hosseini

#### **Description**

This chandelier is designed with the central theme that “beauty isn’t confined to a single moment, it expands, complements, and ultimately becomes evident.” At first glance, viewers perceive the loops of this chandelier, and then they realize the connection of curves that these loops form. This evolving visual rhythm thus soothes observers and reminds them that the serenity of life is an interconnected continuum. In general, the paths taken, the experiences accumulated through setbacks and hardships throughout life, all require the passage of time to reach completion. Essentially, this chandelier is more than a mere fixture. It showcases a glimpse of the intertwined beauty found in life’s moments. Its design is much like interconnected stories that shape our world. As light dances through its graceful arcs, let’s remember the noiseless dance of our own existence.

# Honorable mentions

## Lighting

### OXA

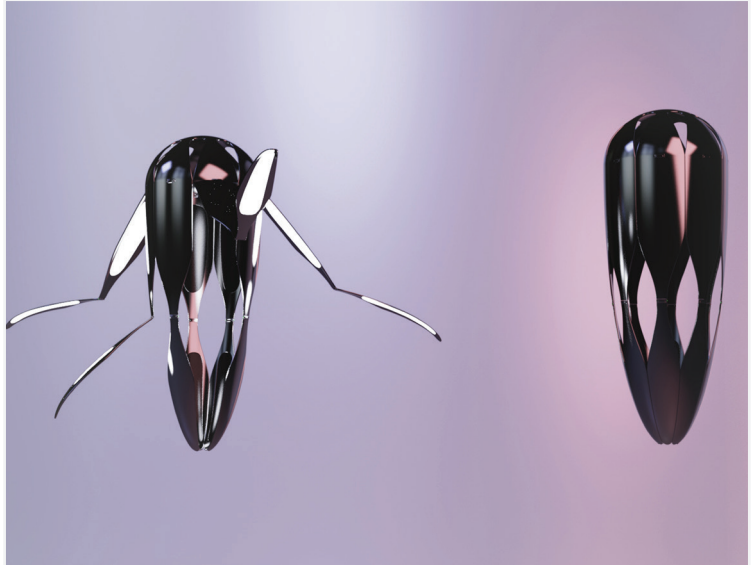
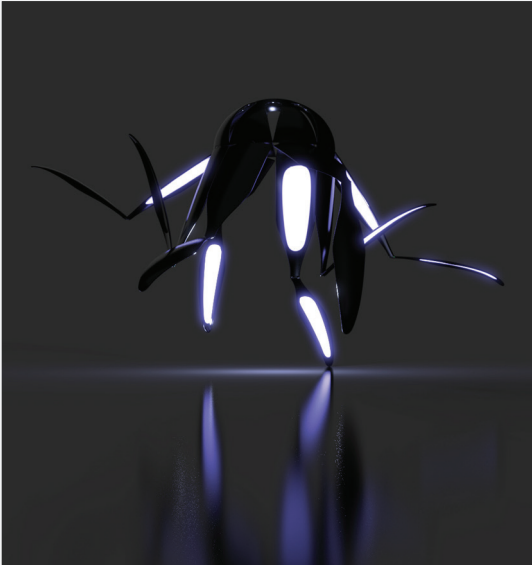

#### Location of the project

Iran

#### Category

Lighting

#### Year of design

2022

#### Designer

Zahra Fathollahi

#### Description

Contemporary spaces require lighting division, which can be achieved by using multiple light sources with different intensity and angles. However, with the design of this lamp, there is no need for multiple light sources for a single space. Each base can be independently adjusted to control the light and angle. This design enables customizable lighting division and angle adjustments in a space. Furthermore, the design of this lamp draws inspiration from the Oxalis plant. In the night, the leaves of this plant connect with each other, and during the day, its petals open up. This inspiration from the two different states of the plant's leaves led to the design of a lamp with the ability to change shape and adjust its light and angle.

# Honorable mentions

## Lighting

### Khorasan



**Location of the project**  
Mashhad/Iran

**Category**  
Lighting

**Year of design**  
2023

**Design team**  
Ali Oraei, Bitá Amel

**Credits**  
Production Assistant: Ali Saravani, Golbarg Zoheyri / Photographer: Javad Rajaei

**Description**  
The idea behind the chandeliers of Khorasan Cafe is inspired by the shape of local clothes of Khorasan dancers during the dance. When you look at the chandeliers of Khorasan Cafe, you can imagine the dancers dancing. The chandeliers are made with the papier-mâché technique, which is made of recycled cardboard and paper materials and is environmentally friendly. The texture and color that you see in the construction is similar to the image of the local houses of Khorasan made of straw and thus maintains its visual connection with the Khorasan region.

# Honorable mentions

## Lighting

---

### Giselle

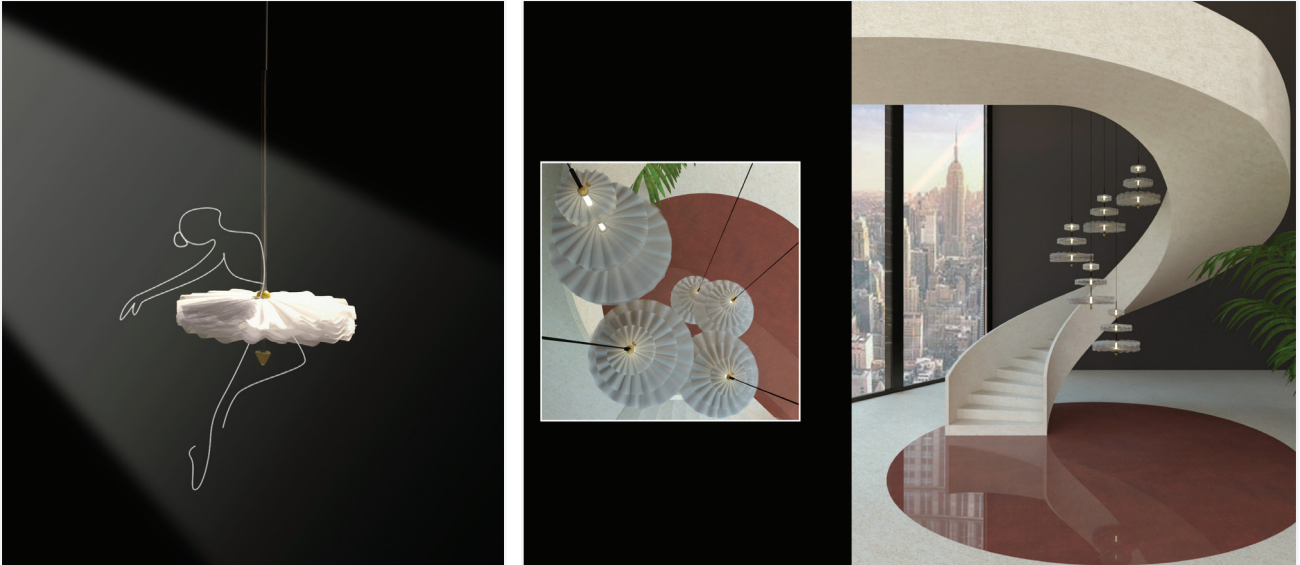

**Location of the project**  
Italy/Switzerland

**Category**  
Lighting

**Year of design**  
2023

**Design team**  
Francesca Garino, Alice Camporese

#### **Description**

This design takes inspiration from ballerinas. The goal was to create a series of light products to represent their grace, lightness and elegance. We created a modular system that can be adapted to all tastes, with three different modules of different sizes that can be combined at wish and can be positioned at different heights. The sustaining pipe has an electric gutter that allows for a flexible system. This product gives its best when many lamps are used together in order to create floating ballet-like coreographies. The use of tulle emphasize this sensation of loveliness. In order to make this product as simple and eco-friendly as possible we designed it without using glue or weldings, easy to ship, assemble and recycle. These lamps can be used in various environments because of their versatility.

# Honorable mentions

## Lighting

### Corps De Ballet



**Location of the project**  
Helsinki/Finland

**Category**  
Lighting

**Year of design**  
2023

**Design team**  
Mira Ollila, Olokoto, Cariitti

**Credits**  
Photography: Kimmo Peranen

#### **Description**

This lamp/piece of art is an ode to the teamwork, to the sisterhood! Together we're more than our sum. The piece consists of 9 sculpted glass ballerinas in a mirrored see-through glassbox. There's a 2W LED under each ballerina to make the figures glow. The reflection multiplies the ballerinas to continue their lines and rows to the eternity. This piece is my "Bravo!" to the corps de ballet dancers' magical illusion of the seamless togetherness. Already the term corps de ballet tells how essential they are for a ballet. They are the core of the piece, the supporting structure of the whole production. I started to sculpt the glass ballerinas more than a year ago. It became an every-day morning routine, almost like a ritual. Just like when being a professional dancer I always started my day by doing a ballet class. A proper warm-up to the glass blowing day with the meditative concentration. This piece of art can also be used as a little coffee table / side table.

# Honorable mentions

## Lighting

### Nira



#### Location of the project

Tehran/Iran

#### Category

Lighting

#### Year of design

2022

#### Design team

Nima Hamedi, Fateme Karim Dehnavi, Kiana Yazdanfar, Zohre Bondar Borji

#### Description

The Pahlavi word “Nira” means light and fire. Nira has a simple and minimal form inspired by a lunar eclipse, and its design is user-friendly, making it easy to use for users. If we consider the moon as the source of light, the surface facing it, by turning 180 degrees, creates different phases of the lunar eclipse. Nira was designed in such a way that it can adjust the light. This table lamp has a cover with a porous surface that can be rotated. When needed, we can adjust it in front of the light source, allowing for the decrease or increase of light. When this cover is completely in front of the light source, the amount of light created is suitable for studying at night. The other part of Nira includes the main axis, which provides the ability to hang and hold it by the user. At the same time, a base is installed to allow it to stand on surfaces. A rechargeable battery is installed in the base of the table lamp, allowing the lamp to be portable. This way, the user can carry it if needed.

# Honorable mentions

## Lighting

---

### Soo

**Location of the project**

Shiraz/Iran

**Category**

Lighting

**Year of design**

2022

**Design team**

Afsoon Hoseinzadeh, Ehsan Varzandiyan

**Description**

Soo literally means Light in our language .this Product is a designed study light, based on minimal mentality that includes the main wooden body, an Iron rod, an Iron bowl shade to place the SMD light in it and also a conversion cable with a USB side to put in the adaptor and a needle power input on the other side to put under the Iron rod for electrification. Its not heavy and It does not take up much space. you can assemble all parts easily.

**Website**

<http://www.afdesigning.com>



# Honorable mentions

## Lighting

### Roshan



#### Location of the project

Iran

#### Category

Lighting

#### Year of design

2023

#### Designer

Azin Rezaei Sanjabi

#### Description

Roshan /rowshan/ in Persian means lit, bright and luminous. The root of the word is similar to Roxana in Greek and Rossana in Italian. Roshan is a portable lamp, inspired by muqarnas, an ornament which had been widely used in Iranian architecture. A muqarnas unit of Nasir Al-Mulk mosque was the origin of the lamp form. In fact, Roshan is an effort to make a contemporary interpretation of the muqarnas unit. Also, the lamp colors are derived from the color palette of the mosque. It is a table lamp, but can also be used as a wall lamp or a floor lamp with the help of a metal rod. There are four magnets on the back cover of the lamp which allows users to change and adjust the direction of light horizontally or vertically. By touching the front face, it will easily be turned on and off. It has a battery in the base of the lamp which can be recharged by using a simple, geometric charger.

# Honorable mentions

## Lighting

### Cylinder



#### Location of the project

Tehran/Iran

#### Category

Lighting

#### Year of design

2023

#### Design team

Parsa Rahmati , Amir saman Sasani

#### Credits

Hamidreza Gozarian

#### Description

The lighting we designed was intended to be used in various places such as:libraries, classrooms,schools,conference rooms,and even in interior decoration.and from the three mains parts of the light panels,smart electric hinges,and the pulleys that were placed in the ceiling mounts.the task of each of these departments is as follow:1-Reel:the task is to adjust the distance between the lighting and the ceiling/2- electric smart hinges:which has the main task of opening and closing the panels from curve to flat mode and also has the task of angling the lighting radiation./3-the main and most important part of lighting is its thin,light and replaceable light panle.

# Honorable mentions

## Furniture and Decorative Items

---

### 4x4

**Location of the project**

Iran

**Category**

Furniture and Decorative Items

**Year of design**

2023

**Designer**

Shayan Ramesht

**Description**

These days, waste production is one of the biggest global issues. Recycling existing materials are way to prevent the generation of less waste. Therefore, the idea of creating a useful object using recycled materials gave birth to of this bench. This bench is made using 16 recycled cardboard tubes. What sets this bench apart is the placement of these tubes at the minimal contact area of the circular section, as overlapping circles tend to slide and fill the empty area. To solve this problem, recycled plastic parts were designed to prevent lateral movement of the tubes when stacked. Plastic straps under pressure to prevent the overall collapse of the bench. In the design of this bench, all materials were used in their raw, emphasizing their aesthetic appeal. The dimensions are 160\*43\*43 cm. It can withstand a weight of up to 230 kg, as tested. For long-term use, cushions made of transparent plastic coverings filled with recycled fabrics have been designed and considered an alternative.

# Honorable mentions

## Furniture and Decorative Items

---

### Cheetah



#### Location of the project

Iran

#### Category

Furniture and Decorative Items

#### Year of design

2021

#### Design team

Shahab Ahmadi, Seyyed Mohammad Hosseini GHaffari

#### Description

Iranian cheetah or Asian cheetah in English is Persian cheetah. Since the 1970s, Iran has been known as the only habitat of Asian (Iranian) cheetahs. The concept of using genes to design the body of the Iranian cheetah, which is the fastest creature on land, which at the same time has a unique balanced movement. Unfortunately, there are only a few maned yurts of this animal left in Iran. It seems that every day a new tool is used to improve the health of our body and soul. The rock chair is one of these tools. At first, the rock chair was Because of its gentle movement, it was mostly used by mothers to hold, sleep, and breastfeed babies. Another advantage of the rock chair is that even if you don't shake it, the chair moves automatically until the center of gravity of the person sitting on it is in line with the center of gravity of the chair. be aligned and in other words reach a balance and being at a balanced angle will bring peace to the user. A rocking chair, whose original name is a rocking chair, is known as a rocking chair in the vernacular of the market.

# Honorable mentions

## Furniture and Decorative Items

---

### Corpo Suspenso

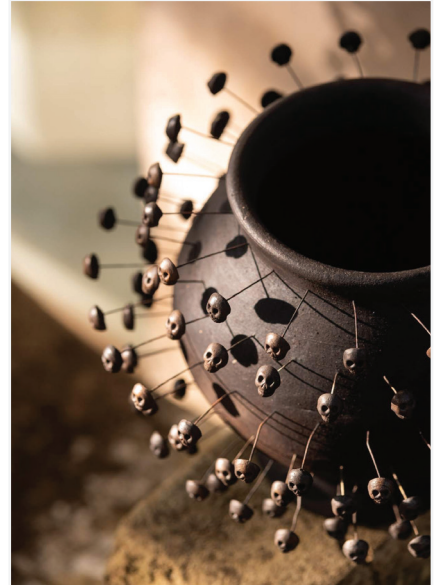

#### Location of the project

Mexico

#### Category

Furniture and Decorative Items

#### Design team

Nina Coimbra, Ceramist Cecílio Sanchez

#### Lead designerDescription

Ceramic Vase with traditional reduction burn with ash. This Vase is a decorative piece created by the meeting of a brazilian designer and a crafts master from Metepec, Mexico. The piece's inspiration is the celebrations and rituals regarding death, the similarities and differences between the brazilian and mexican cultures. It symbolizes the different bodies that separate men from the shadow of death- clay body, vase body, and the ever presence of death that hovers over us.

# Honorable mentions

## Furniture and Decorative Items

---

### Dramalo

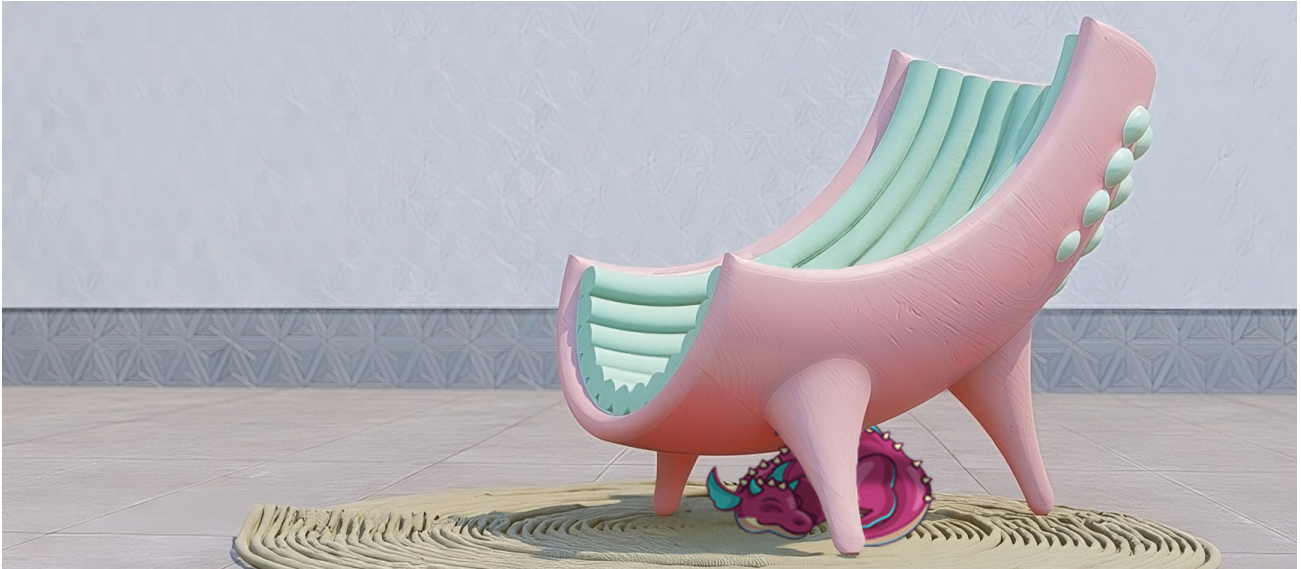

**Location of the project**  
Semnan/Iran

**Category**  
Semnan/Iran

**Year of design**  
2022

**Designer**  
Shahin Nayyer

**Credits**  
Editor: Kimia YarAhmadi, Copywriter: Parsa Mahdavi

**Description**  
Introducing “Dramalo”, a captivating creation that embodies peace and security, providing a sanctuary to rest and rejuvenate, which is inspired from a kind marshmallow-dragon. So you don’t sit on Dramalo, but you fit inside it and the kind dragon hugs you. Inspired by the anime Serendipity, Dramalo’s legs are designed from the shape of the legs and tail and anatomy of the dragon, the small oval volumes on the back of the chair are taken from the bone studs on the back of the dragon; and the seat part of the chair is taken from the form of the parallel lines on the belly of the dragon. Made from premium beech wood, the sofa is covered in poly-urethane and painted meticulously. The seat, made of foam and fabric, ensures utmost comfort.

# Honorable mentions

## Furniture and Decorative Items

---

### Ergobio

**Location of the project**

Iran

**Category**

Furniture and Decorative Items

**Year of design**

2022

**Designer**

Hossein Manouchehri

**Description**

The idea of Ergobio was created with the aim of solving some important problems, firstly, the use of biological and biodegradable materials to protect the environment, such as walnut wood and bamboo mats. secondly, the creation of a curved surface on the seat of the stool allows the user to sit in a different position that reduces pressure on the hip area, for example sitting lengthwise and widthwise of the seating surface. in addition, it is the minimal design style that can reduce production costs due to the lightness of the structure, and the ability to open and close easily by the user.

## Honorable mentions

### Furniture and Decorative Items

---

## Fluid Flow Chair

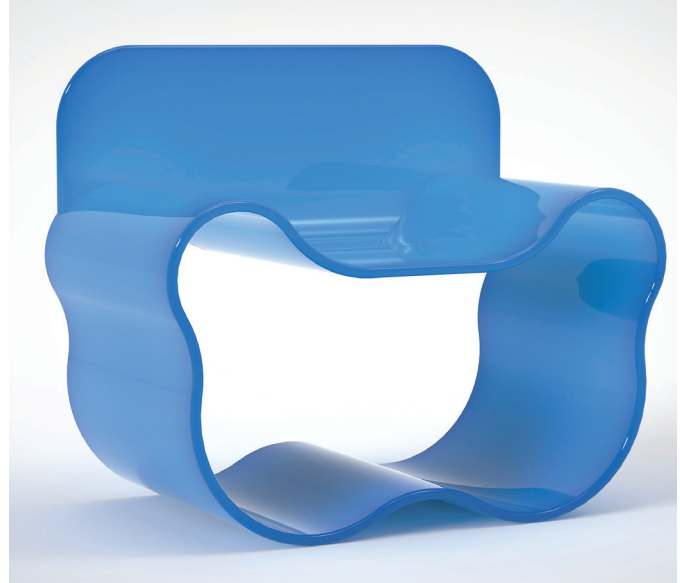
**Location of the project**

Tehran/Iran

**Category**

Furniture and Decorative Items

**Year of design**

2023

**Design team**

Kimia Sharifi, Mohammad (Kia) Hossein Kiarashi

**Credits**

Design, 3D Model & Idea Development: Kimia Sharifi, Render: Mohammad (Kia) Hossein Kiarashi

**Description**

Introducing the epitome of postmodernism and innovation, our groundbreaking polycarbonate transparent chair with an organic shape. Designed to transcend conventional boundaries, this chair embodies the perfect fusion of artistic expression and functional design. Crafted with utmost precision by our team of visionary industrial designers, this chair showcases the seamless integration of form and function. Its transparent polycarbonate construction not only exudes a contemporary aesthetic but also offers exceptional durability, ensuring longevity for years to come. The organic shape of this chair is inspired by nature's graceful curves, evoking a sense of fluidity and harmony. Its unique silhouette effortlessly blends into any space, be it a modern living room, a vibrant office, or even an avant-garde gallery. This chair acts as a captivating centerpiece, captivating attention and sparking conversation with its captivating design. Cats have approved this design as well!!



# Honorable mentions

## Furniture and Decorative Items

---

### Monarc



#### Location of the project

Iran

#### Category

Furniture and Decorative Items

#### Year of design

2023

#### Designer

Ghazaleh Abbasian

#### Description

The design is based on an arch-shaped bridge, which is a convenient form for conducting compressive loads. Additionally, this design incorporates the concept of multi-functionality and flexibility. The whole product consists of two main parts. On top, there is a position for sitting, and on the bottom, there is a support for carrying loads. By rotating the upper part of the seat 180 degrees and changing the position of the main arch, the inner part of the arch could also be used for another function. Depending on the user's interaction, this product can be used in various states. It is generally a chair made of arch-shape plywoods laid side by side. Top components rotate around a hinge to make different form. For further strength, plywood components are continuously incorporated into the support. Small components are embedded to limit the arch swirling.

# Honorable mentions

## Furniture and Decorative Items

### Orumia



#### Location of the project

Isfahan/Iran

#### Category

Furniture and Decorative Items

#### Year of design

2023

#### Designer

Mohammad Meyzari

#### Credits

Inspirator: Farnosh Shams

#### Description

The source of inspiration for the design of this product was Urmia's salt lake. Due to the special importance of this lake in creating favorable weather conditions for its surrounding areas as well as the habitat of rare species of birds, reptiles and animals in the geography of Iran and respect for the environment, the salts of this lake became the source of inspiration for this design, the idea The main design is based on the form that the salts of this lake naturally form by being placed together. Salt has been a symbol of taste, purity, preservation and loyalty. So we placed flames in the middle of this form to be a symbol of it. The most important feature of this product is the use of its sculptural mode, which maintains the visual beauty even when the flames are extinguished. The ability to recharge and use cheap fuel to charge the product, prolonging the burning time and the flame without smoke and odor due to the use of high-quality fuel are among other advantages of this plan.

# Honorable mentions

## Furniture and Decorative Items

### RTA Furniture



#### Location of the project

Iran

#### Category

Furniture and Decorative Items

#### Year of design

2022

#### Designe

Mona Mousavi

#### Description

The purpose of choosing the subject of RTA furniture is to research and investigate the construction of furniture whose components can be easily connected and disconnected by the user. The combination of these features makes furniture easy to transport and move. this furnitures are designed by user- centered dsign metodologies To align this design with the user’s needs and provide more comfort and convenience. Another reason for the success of RTA furniture production around the world is the possibility of easy and cheaper export compared to other existing furniture. Among the other advantages of an assembled sofa, it is possible to check all its components carefully. This is because all the parts can be checked during the installation of each part. For this reason, its faults can be recognized very quickly and the product can be returned to the seller. Finally, all these features made us design and produce this RTA furniture with these features.

# Honorable mentions

## Furniture and Decorative Items

### Sabaah

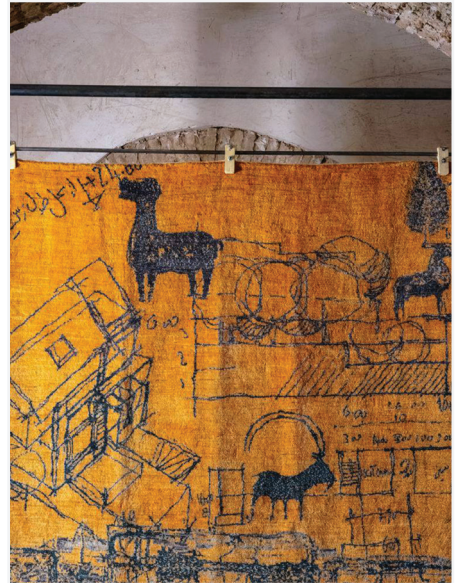

#### Location of the project

Iran

#### Category

Furniture and Decorative Items

#### Year of design

2018

#### Designer

Ali Bazmandegan

#### Description

**Design Elements:** Sabaah is characterized by its restrained colour palette, featuring a deliberate use of only three colours. The carpet showcases an array of motifs, from animals and houses to intricate patterns that evoke both rural life and contemporary design elements. The use of animals harks back to the patterns found in ancient pottery. **Material and Technique:** Sabaah is a testament to the dedication and skill of Iranian artisans. Crafted from hand-spun wool, this labour-intensive process harks back to the traditional practices of old village women. The slow and meticulous creation of the wool speaks to the rich history it carries, while the precision required for spinning underscores the mastery of these artisans. **Texture:** The weaving technique of this carpet is consistent with that of Gabbeh which is an art in Fars, Iran. Iranian Gabbehs are crafted in diverse patterns, including one featuring a fine texture. Similarly, this carpet is woven using the same method.

## Honorable mentions

### Photography and creating photo collages

---

## A memory of your absence



#### Location of the project

Iran

#### Category

Photography and creating photo collages

#### Year of design

2022

#### By

Ali Dinmohammadloo

#### Description

This collection is a true story witnessed by me, depicting the distance between two individuals, forced apart by geographical constraints. Despite their mutual interest, the relationship ultimately ended separately. Through this collection, I aimed to connect with the characters and convey their inner emotions to the outside. The first image portrays an empty frame, symbolizing that although something is missing, the past cannot be denied. In the second picture, the subject holds onto a girl's clothes, suggesting he has achieved what he desired after many years while the girl tries to erase the past in the first picture. Ultimately, the third picture depicts their separation.

## Honorable mentions

### Photography and creating photo collages

---

## Great Women

**Location of the project**

Yazd/Iran

**Category**

Photography and creating photo collages

**Year of design**

2021

**By**

Mehdi Parsaeian

**Description**

In this photo, I tried to combine the symbol of Badgir, which is a sign of the traditional fabric of Yazd city, with women wearing traditional hijab, which are both signs of etiquette. Customs of Yazd city. Also, the composition in this photo is based on rhythm and repeating patterns and simplification. The shape and form of the windbreakers is framed according to the shape and forms of the women sitting on the mat.

## Honorable mentions

### Photography and creating photo collages

---

## Shadow Dance



#### Location of the project

Hamedan/Iran

#### Category

Photography and creating photo collages

#### Year of design

2023

#### By

Amir Hosein Garoosian

#### Credits

Amir Hosein Garoosian

#### Description

These photos were taken in 2023 in Iran, which are the result of playing with ink on paper, and each one has a special and unique shape and story. What each photo shows depends on the viewer's perspective. By looking at these photos, each person may see different shapes, including animals, flowers, and figures.

## Honorable mentions

### Photography and creating photo collages

---

## Wishing for Freedom



#### Location of the project

Tehran/Iran

#### Category

Photography and creating photo collages

#### Year of design

2022

#### By

Fereshte Abdollahimehr

#### Description

In this photo, you can see a woman who is longing for liberation. This woman is in the pit and looks at the sky and the free bird. She wishes to be released like that bird. The woman is in the dark and thinks about the light, and the rays of light are towards her. The woman thinks about liberation. Iranian women are thinking about freedom.



## Honorable mentions

### Photography and creating photo collages

---

## Inside of Me



#### Location of the project

Qom/Iran

#### Category

Photography and creating photo collages

#### Year of design

2023

#### By

Raheleh Etesami

#### Description

Inside me is a different part of us, that we try to hide. sometimes it's colorful and sometimes it'll be colorless. In that case I want to show inside of people.

## Honorable mentions

### Photography and creating photo collages

---

# NO Body Nows Why



#### Location of the project

Iran

#### Category

Photography and creating photo collages

#### Year of design

2023

#### By

Zahra Nazari

#### Description

These portrait photos were taken as a documentary of Muslim women of Islamic countries in the city of Qom, Iran. Sometimes the only cure for a person's pain is to stay away from the pain. A distance that makes you find a better destination for healing. You can't always stay and fight with problems, sometimes you have to leave everything and go.

# Honorable mentions

## Photography and creating photo collages

---

### To Be Or Not To Be

**Location of the project**

Iran

**Category**

Photography and creating photo collages

**By**

Seyyed Mohammad Hosseini Ghaffari

**Description**

The opening phrase of a speech given by Prince Hamlet in the so-called “nunnery scene” of William Shakespeare’s play Hamlet, Act 3, Scene 1

# Honorable mentions

## Photography and creating photo collages

---

### Hidden Voice

**Location of the project**

Bandar Abbas/Iran

**Category**

Photography and creating photo collages

**Year of design**

2022

**By**

Mani Shahzadeh

**Description**

This photo was taken in one of the southernmost cities of Iran, which is called Bandar Abbas. I was photographing these fishing rods called “moshta” and after a few minutes their fisherman came here to check and saw me photographing them and talked to me about how he fishes and What problems does it have. He said: This type of fishing is more suitable for old people who can no longer fish with much activity. When the water is low these sticks are buried in the sand and then a net is attached to it. The problems he had were new to me and it was the first time I heard them. He said: For several years city sewage has been entering this sea and the fishermen’s catch has decreased and I cannot catch many fish with this method and This is a problem for my income and I cannot solve it. At the end of our goodbye he asked me to be his voice and help him with this photo.

# Honorable mentions

## Photography and creating photo collages

---

### Turning Point

**Location of the project**

Olympia Washington/USA

**Category**

Photography and creating photo collages

**Year of design**

2023

**By**

Johnston Roberts

**Credits**

Model: Vivien Rose

**Description**

A portrait that aims to encapsulate the abrupt changes that happen in life. The marble architecture represents the complacency of staying in place while the movement of the dress represent going with the flow. The models movements relate to the unexpected turning points that life has to offer and encapsulates feeling of being swept away with hands splayed upwards as though signaling letting go. All observed through the lens of a wide angle to show that however small the decisions we make, they can still have large reverberations.

# Honorable mentions

## Photography and creating photo collages

---

### Look

**Location of the project**

Iran

**Category**

Photography and creating photo collages

**Year of design**

2023

**By**

Shayan Ramesht

**Description**

This is a single photograph capturing the details of a hidden and discovered Iranian girl. In capturing this portrait, natural ambient light was used, and no artificial lighting was arranged. The conveyance of multiple emotions through one of the most important parts of a portrait photograph, which is the subject's eyes, has taken place.

## Honorable mentions

### Graphic Design and Visual Communication

---

## Altavita

**Location of the project**

Iran

**Category**

Graphic Design and Visual Communication

**Year of design**

2015

**Designer**

Roosbeh Mashhadizadeh

**Description**

Altavita company focuses on importing special doors with different designs for use in kitchen cabinets from Italy, as well as designing the entire kitchen. The shape of open and closed door (in perspective) is used in the design. To induce more movement and volume, red and black colors with their problematic tonalities have been used.

# Honorable mentions

## Graphic Design and Visual Communication

### Font Catalog



#### Location of the project

Istanbul/Turkiye

#### Category

Graphic Design and Visual Communication

#### Year of design

2023

#### Designer

Elif Baydilli

#### Description

The font catalog provides convenience to designers by collecting world-renowned font designs in a single book. There are 28 fonts in the book. Description of these 28 fonts and majiscule/miniscule letters are also included. In addition, there are separate banner designs for each font. Thus, when designers want to use a font, they can find the most suitable font with the help of the catalog and make their design unique.



# Honorable mentions

## Graphic Design and Visual Communication

### Mont Bromo Perfume



#### Location of the project

Iran

#### Category

Graphic Design and Visual Communication

#### Year of design

2023

#### Designer

Azadeh Yaftiyan

#### Description

The name of this perfume brand is derived from the volcano Mount Bromo. And it was decided that the box should look like a mountain at first glance, and therefore, apart from the beauty of the box, the health of the product is also an essential element. Inside the perfume boxes, they put inners so that they are not lost during export and transportation of the product, and these inners are basically one layer, but in order to be able to show the role of the mountain in this box, I considered three layers, and the outer box is in the shape of a triangle like I blanked the mountain sign so that the mountains are visible inside. On the body of the outer box, a mountain pattern is highlighted, which continues when several boxes are placed on different sides. This product includes women's and men's fragrances, the women's box is white and the men's box is black, but the inners of both boxes are of the same copper color, which when placed together shows a complete mountain.

# Honorable mentions

## Graphic Design and Visual Communication

### Promise



**Location of the project**  
Shiraz/Iran

**Category**  
Graphic Design and Visual Communication

**Year of design**  
2022

**Design team**  
Mohammad Khademi, Atefe Sianat

#### Description

Octa Art Magazine, published on a monthly and bi-monthly basis, features a unique concept each month in relation to time, events, and selected artworks. Each of these final concepts, like the submitted artworks, requires a different design layout, color scheme, and design scenario. Our team is responsible for selecting the concept and creating a new scenario each month. We strive to incorporate relevant authentic elements, events, and harmonious colors in all designs, primarily related to Iranian events and artists. We make an effort to use Iranian authentic colors and elements in a new design format while preserving the identity. Furthermore, to better maintain the identity, all elements have been arranged together as a cohesive family, so that each month's artworks, artists, professors, colors, naming, layout, etc., have a shared and unified feel. All of these scenario writings, color selections, designs, and edits have been carried out by our design team.

## Honorable mentions

### Graphic Design and Visual Communication

## Royaye Zamin

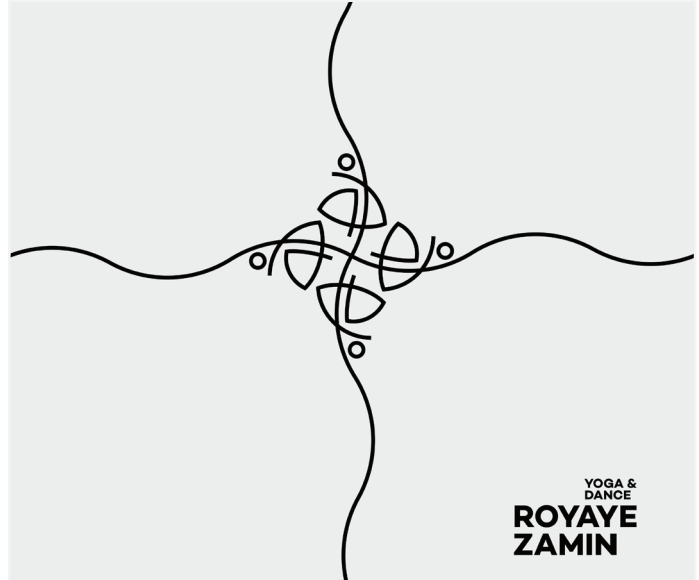

#### Location of the project

Tehran/Iran

#### Category

Graphic Design and Visual Communication

#### Year of design

2020

#### Designer

Sima Saffari

#### Description

The story of this project is about a woman who is a yoga instructor and a dance teacher. We are faced with a path in the education system and in this path we have a coach who teaches us. I designed the logora form as a path and displayed the body in this path. What is done in yoga is inspired by Rumi's poem "dar sama aio ze sar kherghe bar andazo beraghs".

# Honorable mentions

## Graphic Design and Visual Communication

### Gosh Shenava

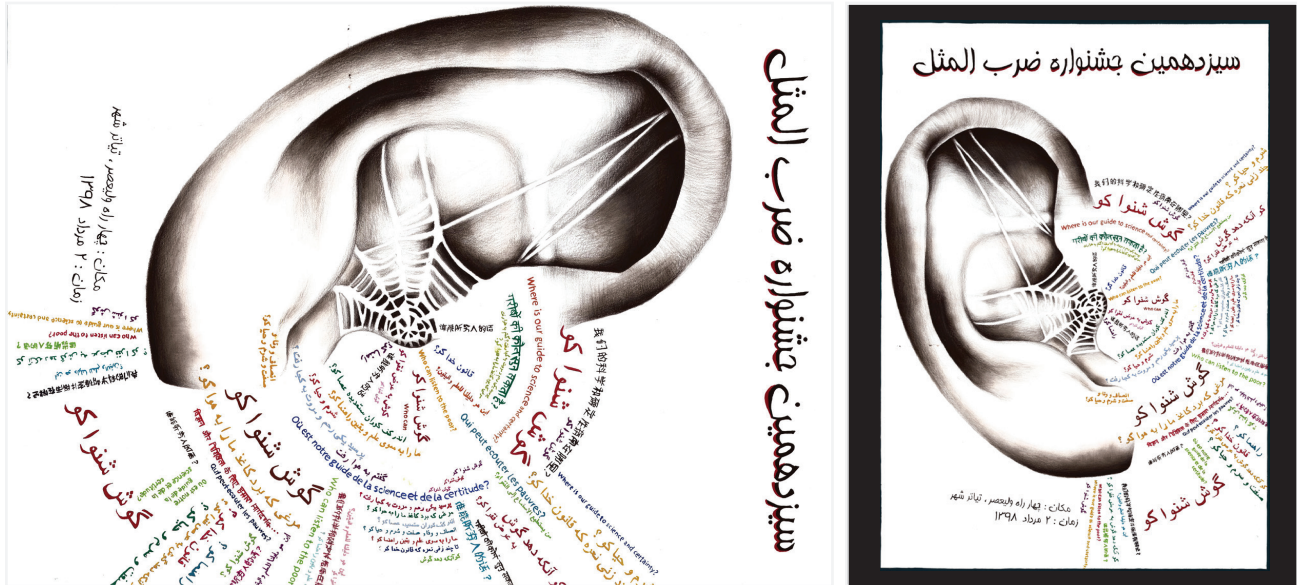

#### Location of the project

Tehran/Iran

#### Category

Graphic Design and Visual Communication

#### Year of design

2023

#### Designer

Ailar Nadimi

#### Description

One of the most famous and practical Persian proverbs is the “koo goosh-e shenavaa” proverb which means, one is talking while the other person is not paying any attention to him/her. The point of this proverb is to complain about the considered person not willing to listen to anything at all. We chose this proverb and designed a poster for the proverb festival with the following details: -the poster has A1 dimensions and materials such as colored pencils and gouache paint is used. -the general silhouette of the poster contains the shape of an ear in which there’s a spider net that thickens as you move deeper in the hearing chamber and on the other side you can see the Seyed Ashraf al-din Hosseiny’s profound poem in different languages which says “where’s the ear that listens?” and it indicates that the person is not willing to listen and perceive you, no matter the spoken language.

# Honorable mentions

## Graphic Design and Visual Communication

### Fotile



#### Location of the project

Tehran/Iran

#### Category

Graphic Design and Visual Communication

#### Year of design

2021

#### Designer

Nazanin Farhadi

#### Description

In 2013, it became the most famous and popular brand in Iran, Singapore, Malaysia, Pakistan and dozens of other countries. .in 2002 due to professionalism and high quality opened its way in global markets and in 2004 with a long-term vision, it focused on exploring global markets and gaining foreign business opportunities and started the production abroad.. In 2010, in 2010, the Futail brand of its products with global quality and unique design as the top flower of the kitchen products basket Cooking lovers in the world. I have compiled and designed the catalog and brochure of these products in Iran in 2021 and I tried to make the catalog very minimal according to the design of the products.

# Honorable mentions

## Graphic Design and Visual Communication

### A1 Design



#### Location of the project

Tehran/Iran

#### Category

Graphic Design and Visual Communication

#### Year of design

2021

#### Designer

Roozbeh Mashhadizadeh

#### Description

A1 Design Trading and Design Group supplies premium parquet and wooden floors, integrated into architectural projects. The logo incorporates the capital letter "A" and the numeral "1," aligned with the company's name. The isometric perspective underscores its core activity, while the combination of dark orange and black hues evokes the warmth of wood and its inviting ambiance.

# Honorable mentions

## Graphic Design and Visual Communication

---

### Target

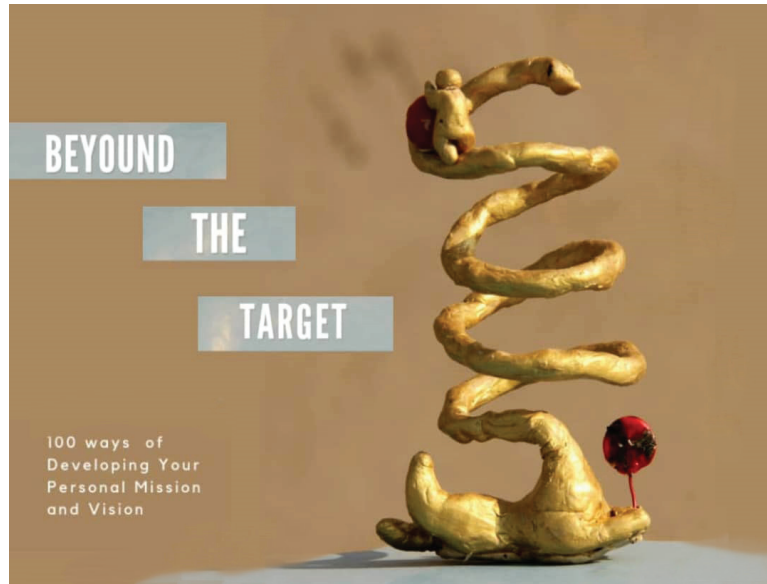

**Location of the project**

Tehran/Iran

**Category**

Graphic Design and Visual Communication

**Year of design**

2023

**Designer**

Atiyeh Vadood

**Description**

The design of the book cover is based on the concept of title and subtitle. Title: "Beyond the Goal" Subtitle: "100 Ways to Develop Your Personal Mission and Vision" The stages of project implementation include the following items, in order: preliminary design, making a sculpture based on the preliminary design, photographing the sculpture, using photos for the cover design.

# Honorable mentions

## Graphic Design and Visual Communication

### Biohuner



#### Location of the project

Tehran/Iran

#### Category

Graphic Design and Visual Communication

#### Year of design

2021

#### Designer

Setareh Rahgard Nobari

#### Credits

Consultant: Bahareh Rahgard Nobari

#### Description

This logo belongs to Biohuner Design Studio, which combines medicine and industrial design to improve human life. The logo consists of two flexible lines that form the shape of two intertwined B letters. The first B represents the two areas of work of this brand, while their entanglement represents their combination and integration. The second B is placed in the opposite direction to the first one, and its stem is at the bottom, indicating that this brand covers all areas of work in these fields. Additionally, there is a hidden symbol in the logo where the two B letters are intertwined to indirectly refer to the DNA symbol.





[award.kioskedia.com](http://award.kioskedia.com)

## Contact US:

For questions and remarks of the KIOSKedia International Design Award, please feel free to contact us

Email:  
[award@kioskedia.com](mailto:award@kioskedia.com)

Website:  
[award.kioskedia.com](http://award.kioskedia.com)